



PREFERRED BEST MANAGEMENT PRACTICES FOR CONSTRUCTION ACTIVITIES



Adopted June 13, 2016

Revised **December 20, 2024**

BMP REFERENCE MANUAL

This manual is intended as guidance for implementing Stormwater Best Management Practices (BMP's) at construction sites that are preferred. As it does not represent all BMPs, but rather a presentation of the more common BMP's accepted by South Jordan City. The site should be evaluated to ensure the selected BMP(s) are suitable and may need additional consideration of BMPs based on site conditions and construction operations. Conditions such as slope, proximity to water, soil type, infiltration rate, feasibility, etc. should all be considered. BMPs that do not meet their performance criteria can result in oversight authority notice of Storm Water Pollution Prevention Plan (SWPPP) violation(s) and potential enforcement.

South Jordan City cannot be held liable for special, collateral, incidental or consequential damages in connection with or arising from using techniques presented in this manual.

PURPOSE

The purpose of this BMP Manual is to meet the requirements of Utah Code 19-5-108.3. Each MS4 in the State of Utah will select which BMPs they preferred and are acceptable for use within their jurisdiction at permitted construction sites.

STORMWATER AND CONSTRUCTION ACTIVITIES

A landowner or primary contractor who plans or conducts construction activity with a land disturbance of greater than or equal to one acre, including projects less than one acre that are part of a larger common plan of development or sale is required to obtain a permit from the Utah Division of Water Quality. The permit may be obtained on-line at: <https://deq.utah.gov/water-quality/general-construction-storm-water-updes-permits>.

Please note that the permit is required **BEFORE** construction starts. The permit requires the development and implementation of a Storm Water Pollution Prevention Plan (SWPPP) that identifies potential sources of Stormwater pollutants and Best Management Practices (BMPs) to reduce or eliminate their impacts.

BMPs are practices that control stormwater sediment and erosion to the maximum extent practicable (MEP). These controls include a wide range of structural and non- structural options. This booklet presents BMPs that are recommended by the Utah Division of Water Quality and the Environmental Protection Agency.

Contractors/Operators are to use this booklet as general guidance related to the BMPs preferred in South Jordan; it is up to the contractor to select appropriate BMPs and implement and maintain these BMPs specifically as described. Selection of BMPs will be site specific in containing and managing the site's unique exposures and construction operations. The implementing or use of multiple (joining) BMP's is encouraged to help increase or improve the control or pollutants runoff, as long as they are from the preferred list or have been approved by the authoritative agency.

Deviation from those presented here may be appropriate given the conditions, contractor experience and new technology. Operators are invited to use an alternative BMP or modify a BMP from the Preferred List so long as the BMP has the same performance criteria or better as the preferred BMP. Any deviations from the preferred BMP installation and use parameters must be reviewed and accepted by the oversight authority. See Adding an Alternative BMP – Template below:

Stormwater pollution control requirements are intended to be proactive and implemented on a year-round basis. Appropriate pollution control includes both erosion control and sediment mitigation as well as track out controls, non-stormwater discharge and waste management, and material pollution BMPs. Some BMPs can be implemented as a stand-alone device while others can be combined to improve effectiveness and compliance.

Template for Adding an Alternate BMP (Operator Version)

[BMP # - Title]

Replace all blue text in brackets with BMP specific data. Then delete any remaining unnecessary blue instructional text.

[Insert the BMP detail drawing specific to the proprietary device you will use. It should illustrate the structure of the BMP, installation requirements, and any typical variances due to site conditions.]

[IMAGE]

APPLICATION

- [Describe specifically when and where this BMP will be used on site]

INSTALLATION/USE PROCEDURES

- [Describe how this BMP should be installed or how it should be practiced]
- [Describe further so that it is very clear, such as minimum length of structure, etc.]

BMP MODIFICATION OR REPLACEMENT JUSTIFICATION

Use only one of the two following bullets

- This BMP is replacing or augmenting [list the preferred BMP that is being replaced] OR
- This BMP is being added and implemented as the conditions or operations cannot be adequately managed by a BMP from the USWAC Preferred List.

MAINTENANCE/MANAGEMENT

- [Add maintenance criteria for proper BMP performance]
- [Describe how the BMP should look or function during an inspection]
- [Describe when maintenance is necessary]
- [Describe when replacement is necessary]
- [Describe when no action is needed]

PERFORMANCE

- [Describe performance expectations of the alternative BMP. This includes how it protects water resources, manages hazards, and limits public complaints]

GENERAL

- [Include other information, direction, instruction, and BMP criteria that does not fit well into the other categories.]

REFERENCE

- [CGP and Federal Regulations sections, numbers, link to proprietary documentation, etc.]

ADDITIONAL INFORMATION

Salt Lake County Stormwater Coalition

<http://www.stormwatercoalition.org/>

Salt Lake County Department Flood Control Engineering

<http://www.pweng.slco.org/flood/index.html>

Salt Lake County Public Works Stormwater Management

www.pweng.slco.org/strm/html/guide.html

State Division of Water Quality

<http://www.waterquality.utah.gov/UPDES/stormwater.htm>

US Environmental Protection Agency

http://cfpub1.epa.gov/npdes/home.cfm?program_id=6

Center for Watershed Protection

<http://www.cwp.org/>

Low Impact Development

<http://www.lid-stormwater.net/>

StormCon

<http://www.forester.net/sc.html>

Water Environment Federation

<http://www.wef.org/Home>

Stormwater Authority

<http://www.stormwaterauthority.org/>

Table of Contents

| | |
|----------------------------------------------------------|----|
| BMP: Benching..... | 1 |
| BMP: Bioengineering | 2 |
| BMP: Building Repair, Remodeling, and Construction | 3 |
| BMP: Check Dams | 4 |
| BMP: Check Dams with Rock in Channels..... | 5 |
| BMP: Check Dams with Straw Wattles in Channels..... | 8 |
| BMP: Chemical Mulch | 10 |
| BMP: Chemical/Hazardous Material Management..... | 11 |
| BMP: Compaction | 12 |
| BMP: Concrete Washout Pan | 13 |
| BMP: Concrete Washout Ground Fixed Systems..... | 16 |
| BMP: Concrete Washout Small Management Operations..... | 20 |
| BMP: Concrete Waste Management..... | 22 |
| BMP: Construction Dewatering DEQ Permit Required | 23 |
| BMP: Construction Dewatering Retention | 24 |
| BMP: Construction Track-out Controls..... | 25 |
| BMP: Construction Road Riffle Boards | 27 |
| BMP: Construction Parking Pad & Supplier Access..... | 29 |
| BMP: Construction Sequencing..... | 31 |
| BMP: Contaminated or Erodible Surface Areas..... | 32 |
| BMP: Curb Sedimentation Trap | 33 |
| BMP: Diversion Dike | 35 |
| BMP: Dust Controls..... | 37 |
| BMP: Earth Berm Barrier | 38 |
| BMP: Employee Training..... | 39 |
| BMP: Equipment & Vehicle Wash Down Area | 40 |
| BMP: Erosion Control Blankets | 41 |
| BMP: Filter Strips..... | 42 |
| BMP: Final Stabilization..... | 43 |
| BMP: Floatation Silt Curtain | 44 |
| BMP: Fugitive Dust Control Plan..... | 45 |
| BMP: Geotextiles and Mats..... | 46 |

| | |
|-----------------------------------------------------------|----|
| BMP: Gutter Dams | 47 |
| BMP: Hazardous Waste Management | 49 |
| BMP: Hydromulching..... | 51 |
| BMP: Inlet Protection - Excavated | 52 |
| BMP: Inlet Protection – Drop Inlet w/Overflow | 53 |
| BMP: Inlet Protection – Drop Inlet w/Overflow 2 | 55 |
| BMP: Inlet Protection – Sand/Gravel Filtration Bags | 56 |
| BMP: Inlet Protection – Silt fence or Straw Bales | 58 |
| BMP: Inlet Protection –Wattle..... | 59 |
| BMP: Inspection and Maintenance..... | 60 |
| BMP: Land Grading..... | 61 |
| BMP: Manual Mud Removal..... | 62 |
| BMP: Material Storage | 64 |
| BMP: Material Use | 65 |
| BMP: Mulching | 66 |
| BMP: Onsite Equipment Fueling..... | 67 |
| BMP: Outlet Protection..... | 69 |
| BMP: Outlet Protection- Culvert Sediment Barrier..... | 70 |
| BMP: Pavement Saw Cutting- Dry..... | 72 |
| BMP: Pavement Saw Cutting- Wet | 73 |
| BMP: Portable Sediment Tank | 75 |
| BMP: Portable Toilets..... | 77 |
| BMP: Portable Toilets- Mounted..... | 79 |
| BMP: Preservation of Existing Vegetation..... | 81 |
| BMP: Sandbag Barrier | 82 |
| BMP: Sediment Basin..... | 83 |
| BMP: Sediment Trap | 85 |
| BMP: Silt Fence..... | 86 |
| BMP: Slope Drain..... | 88 |
| BMP: Slope Drain – Filter Tubes | 89 |
| BMP: Solid Waste Management..... | 91 |
| BMP: Spill Clean-Up..... | 93 |

| | |
|----------------------------------------------------|-----|
| BMP: Stockpile Management | 94 |
| BMP: Straw Bale Barrier | 95 |
| BMP: Street Sweeping..... | 96 |
| BMP: Temporary & Permanent Seeding & Planting..... | 98 |
| BMP: Temporary Drains and Swales | 99 |
| BMP: Vegetated Buffers..... | 100 |
| BMP: Vegetation Removal Phasing | 101 |
| BMP: Vehicle and Equipment Cleaning..... | 102 |

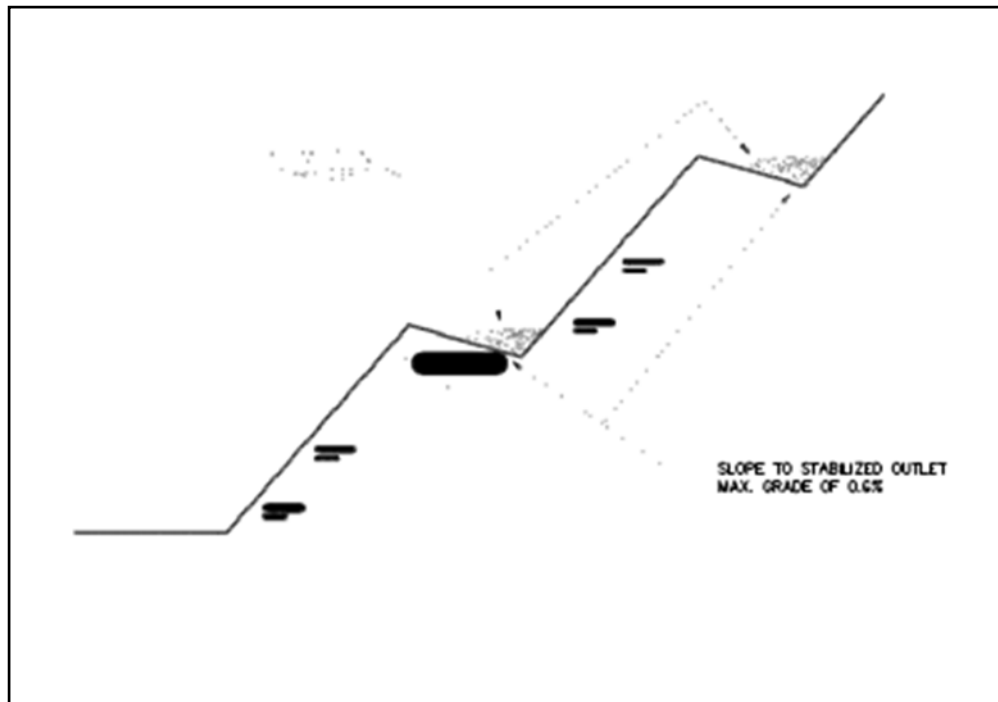
**DESCRIPTION:**

Slope construction with benches spaced at regular intervals perpendicular to the slope which intercept and collect sheet flow and direct it to a stable outfall point.

APPLICATIONS:

- ◆ Unstabilized cut and fill slopes
- ◆ Large stockpiles
- ◆ Existing unstable slopes

INSTALLATION/APPLICATION CRITERIA:

- ◆ Benches should be formed as slope is constructed and graded to the outlet point.
- ◆ Stabilized outlet with sediment controls should be in place prior to slope construction.

LIMITATIONS:

- ◆ Construction slope design must accommodate benching
- ◆ Not appropriate for sandy or rocky soil
- ◆ Only effective if suitable outlet provided

MAINTENANCE:

- ◆ Inspect after major storm events and at least biannually, repair any damaged areas.
- ◆ Remove debris blocking water flow.
- ◆ Inspect outlet, repair/replace sediment controls and remove sediment build up.
- ◆ Inspect outlet, repair/replace sediment controls and remove sediment build up.

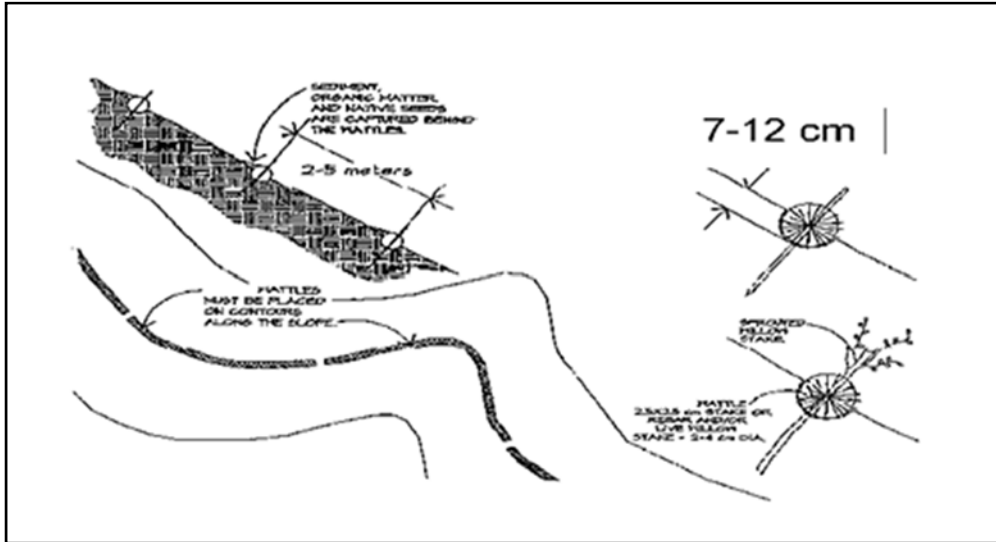

DESCRIPTION:

Bioengineering methods combine vegetative and mechanical techniques to stabilize eroding slopes. Bioengineering methods include sprigging, tubeling and wattling. Sprigging involves planting rhizomes, stolons, shoots or sprouts of a desirable species. Tubelings are forbs, shrubs, or trees commercially available in reusable plastic tubes or sleeves. Wattles are bundles of cuttings from live willows, alders, or similar plants placed and secured in trenches across a slope to aid in slope stabilization.

APPLICATIONS:

- ◆ Sprigging may be performed on cut and fill slopes or other areas needing permanent soil stability.
- ◆ Tubelings may be placed on any area needing revegetation, but are most useful on slopes or flat areas where poor topsoil conditions inhibit successful seed germination and early plant growth.
- ◆ Wattles act to reduce slope length and aid in stabilizing slopes due to surface runoff, frost heaving, needle ice, or other soil movement.

INSTALLATION/APPLICATION CRITERIA:

- ◆ Sprigging involves tearing sod apart; planting rhizomes or stolons, or transplanting shoots or sprouts.
- ◆ Sprigs are placed by broadcast, punching-in or with a special sprig planter.
- ◆ Tubelings involve drilling holes to the depth necessary to accommodate roots.
- ◆ Wattles are best applied to slopes no steeper than 2:1.

LIMITATIONS:

- ◆ Availability of plant materials may affect what species can be used.
- ◆ May be necessary to arrange for commercially grown tubelings.
- ◆ Cannot be used as a substitute for retaining walls or similar devices to stabilize over steepened slopes

MAINTENANCE:

- ◆ Sprigging and tubeling plantings should be checked periodically until they are permanently established.
- ◆ Assess the need for replacement plantings or supplemental fertilizer.

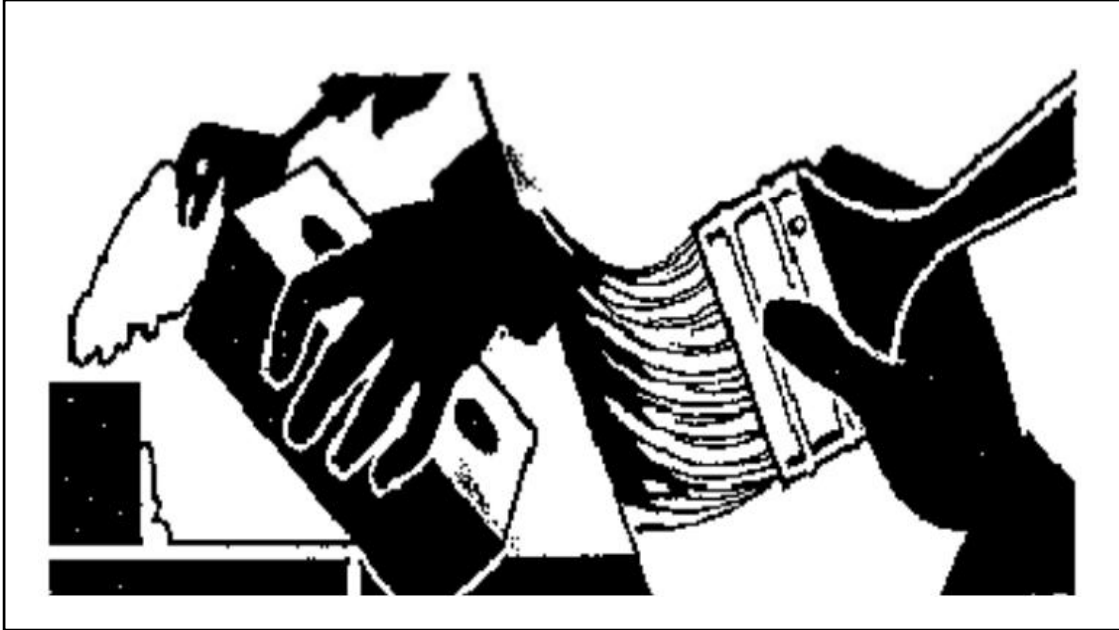

DESCRIPTION:

Prevent or reduce the discharge of pollutants to stormwater from building repair, remodeling, and construction by using soil erosion controls, enclosing or covering building material storage areas, using good housekeeping practices, using safer alternative products, and training employees.

APPLICATIONS:

- ◆ Use soil erosion control techniques if bare ground is temporarily exposed.
- ◆ Use permanent soil erosion control techniques if the remodeling clears buildings from an area that are not to be replaced.

INSTALLATION/APPLICATION CRITERIA:

- ◆ Enclose painting operations consistent with local air quality regulations and OSHA.
- ◆ Properly store materials that are normally used in repair and remodeling such as paints and solvents.
- ◆ Properly store and dispose waste materials generated from the activity.
- ◆ Maintain good housekeeping practices while work is underway.

LIMITATIONS:

- ◆ This BMP is for minor construction only.
- ◆ A licensed hazardous waste hauler must dispose of hazardous waste that cannot be re – used or recycled.
- ◆ Safer alternative products may not be available, suitable, or effective in every case.
- ◆ Be certain that actions to help storm water quality are consistent with OSHA and air quality regulations.

MAINTENANCE:

None

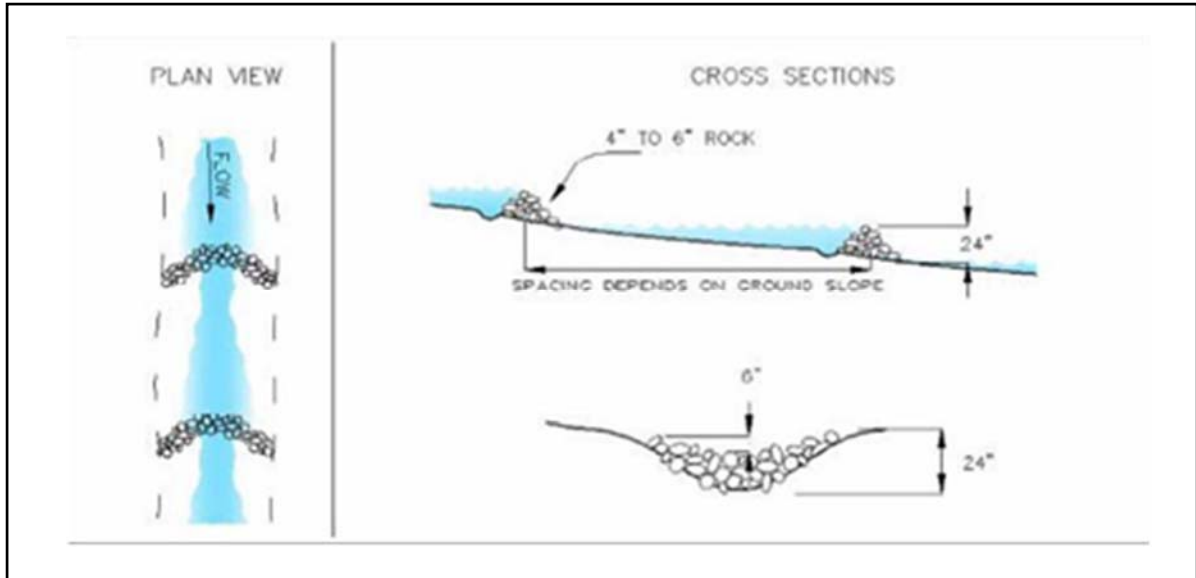

DESCRIPTION:

A small, temporary dam constructed across a drainage ditch to reduce velocity of concentrated storm water flows, thereby reducing the erosion of the ditch.

APPLICATIONS:

- ◆ Temporary drainage paths
- ◆ Permanent drainage ways not yet stabilized
- ◆ Existing drainage paths receiving increased flows due to construction

INSTALLATION/APPLICATION CRITERIA:

- ◆ Prepare location of dam by removing any debris and rough grading any irregularities in channel bottom.
- ◆ Place rocks by hand or with appropriate machinery; do not dump.
- ◆ Space dams to make the base of the upstream dam the same elevation as the top of the next lower dam.
- ◆ Construct dam to pass design flows with center lower to create a weir effect.
- ◆ Construct 50% side slopes on dam.

LIMITATIONS:

- ◆ Maximum recommended drainage area is 10 acres.
- ◆ Maximum recommended height is 24".
- ◆ Do not use in running stream.

MAINTENANCE:

- ◆ Inspect dams at a minimum of twice monthly, after each major rain event, and daily during prolonged rainfall.
- ◆ Remove any large debris and repair any damage to dam, channel or side slopes.
- ◆ Remove accumulated sediment when it reaches one half the height of the dam.
- ◆ Remove accumulated sediment when it reaches one half the height of the dam.

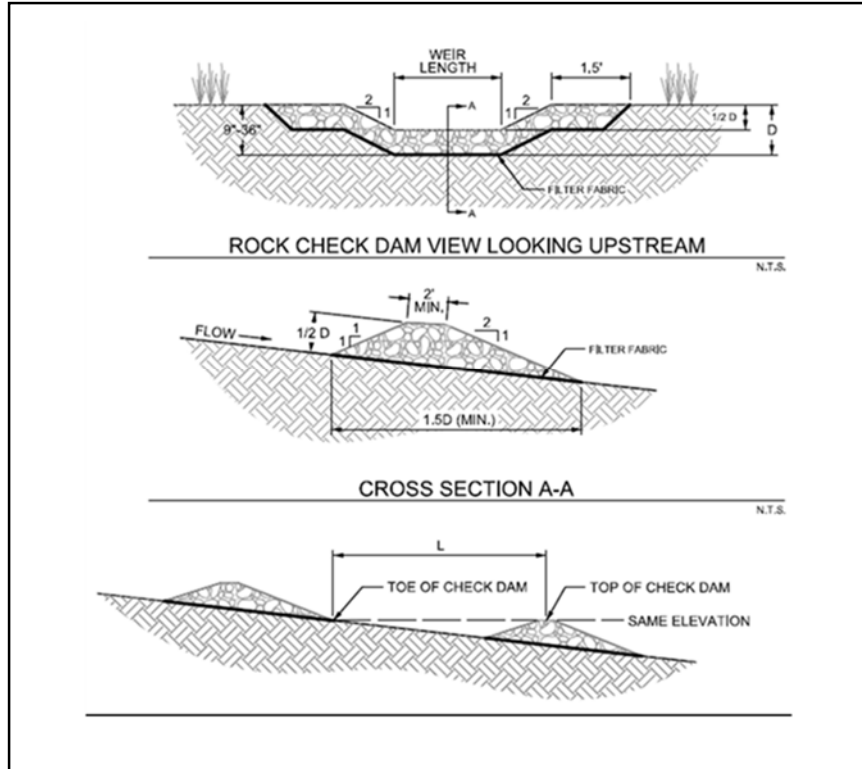

APPLICATION:

- ◆ Check dams are used in swales and drainage ditches (including those along linear projects such as roadways).
- ◆ They can also be used in short swales down a steep slope to reduce velocities.
- ◆ Check dams shall not be used in live stream channels.
- ◆ Check dams should be installed before the contributing drainage area is disturbed, so as to mitigate the effects on the swale from the increase in runoff.
- ◆ If the swale itself is graded as part of the construction activities, check dams are installed immediately upon completion of grading to control velocities in the swale until stabilization is completed.

INSTALLATION/USE PROCEDURES:

- ◆ Install rock check dam per illustrated detail. D=24" or less and install the center of the dam about 6" lower than the sides.
- ◆ Check dams should be used in conjunction with other sediment reduction techniques prior to releasing flow offsite.
- ◆ Use 4" or greater rock diameter and non-woven geotextile fabric under check dams of 12 inches in height or greater. When high flow rates and velocities are anticipated engineering is required.
- ◆ Dam height should be between 9 and 36 inches and less than one-third the depth of the channel
- ◆ Dams should be spaced such that the top of the downstream dam is at the same elevation as the toe of the upstream dam. On channel grades flatter than 0.4 percent,

check dams should be placed at a distance that allows pools to form between each check dam.

- ◆ The top of the side of the check dam shall be a minimum of 12 inches higher than the middle of the dam. In addition, the side of the dams shall be embedded a minimum of 18 inches into the side of the drainage ditch, swale or channel to minimize the potential for flows to erode around the side of the dam.
- ◆ Use geotextile fabric (of appropriate tensile strength, puncture rating and apparent opening size) under check dams of 12 inches in height or greater.
- ◆ Loose soil, wood chips, compost, and other floatable materials that are transportable during runoff should not be used to construct a check dam.

ALTERNATIVE DESIGN:**Rock Check Dams:**

- ◆ Stone shall be well graded with stone size ranging from 3 to 6 inches in diameter for a check dam height of 24 inches or less. The stone size range for check dams greater than 24 inches is 4 to 8 inches in diameter.

Rock Bag Check Dams:

- ◆ Rock bag check dams should have a minimum top width of 16 inches.
- ◆ Minimum rock bag dam height of 12 inches would consist of one row of bags stacked on top of two rows of bag. The dam shall always be one more row wide than it is high, stacked pyramid fashion.
- ◆ Bags should be filled with pea gravel, filter stone, or aggregate that is clean and free of deleterious material.
- ◆ Sand bags shall not be used for check dams, due to their propensity to break and release sand that is transported by the concentrated flow in the drainage swale or ditch.
- ◆ Bag material shall be polypropylene, polyethylene, polyamide or cotton burlap woven fabric, minimum unit weight 4-ounces-per-square-yard, Mullen burst strength exceeding 300-psi as determined by ASTM D3786, Standard Test Method for Hydraulic Bursting Strength of Textile Fabrics-Diaphragm Bursting Strength Tester Method, and ultraviolet stability exceeding 70 percent.
- ◆ PVC pipes may be installed through the dam to allow for controlled flow through the dam. Pipe should be schedule 40 or heavier polyvinyl chloride (PVC) having a nominal internal diameter of 2 inches.

Sack Gabion Check Dams:

- ◆ Sack gabion check dams may be used in channels with a contributing drainage area of 5 acres or less.
- ◆ Sack gabions shall be wrapped in galvanized steel, woven wire mesh. The wire shall be 20 gauge with 1 inch diameter hexagonal openings.
- ◆ Wire mesh shall be on piece, wrapped around the rock, and secured to itself on the downstream side using wire ties or hog rings.
- ◆ Sack gabions shall be staked with $\frac{3}{4}$ inch rebar at a maximum spacing of three feet. Each wire sack shall have a minimum of two stakes.
- ◆ Stone shall be well graded with minimum size range from 3 to 6 inches in diameter.

Organic Filter Tube Check Dams:

- ◆ Organic filter tubes may be used as check dams in channels with a contributing drainage area of 5 acres or less.
- ◆ Organic filter tubes shall be a minimum of 12 inches in diameter.
- ◆ Filter material used within tubes to construct check dams shall be limited to coir, straw, aspen fiber and other organic material with high cellulose content. The material should be slow to decay or leach nutrients in standing water.
- ◆ Staking of filter tubes shall be at a maximum of 4 foot spacing and shall alternate through the tube and on the downstream face of the tube.

OPERATOR BMP MODIFICATION OR REPLACEMENT:

- ◆ Operator is invited to propose an alternative BMP or modify this preferred BMP. The proposed BMP must match or exceed performance requirements as this preferred BMP. Any deviations from this preferred BMP must be reviewed and accepted by the oversight authority.
- ◆ Submit BMP modifications or replacements to the oversight authority for review; including but not limited to; Proprietary system literature, modified illustrations, any operation procedures and maintenance adjustments, etc.

MAINTENANCE/MANAGEMENT:

- ◆ Inspect the check dam system each report period and after storm events.
- ◆ Remove silt when sediment accumulation reaches approximately 1/3 the height of the dam.
- ◆ Inspect for erosion beneath and around the check dam (particularly where the edge of the dam meets the side of the channel) and restore as needed each report period.
- ◆ If erosion continues to be a problem, modifications to the check dam or additional controls must be engineered.

PERFORMANCE:

- ◆ Check dam systems are intended to perform as engineered up to .25" of rain fall
- ◆ Rock check dams are performing as intended if the drainage channel they are protecting does not develop deep erosive gulley's between dams and the dam itself is not being undercut by erosion or eroded to either side of the dam.
- ◆ Due to the minimal sediment capture capability of check dams, good performance will include accumulations of sediment on the upstream side of dams between maintenance intervals.

It is considered a BMP failure when any of the following occur:

- ◆ System not installed per illustrated detail, system not maintained, or system damaged by construction operations.
- ◆ Erosion damage resulting in variance from detail dimensions.

REFERENCE:

U-CGP 2.2.11 – “Minimize erosion of constructed or natural site drainage feature channels and their embankments, outlets, adjacent streambanks, slopes, and downstream waters. Use erosion controls and velocity dissipation devices within and along the length of any constructed or natural site drainage feature channel and at any outlet to slow down runoff and minimize erosion

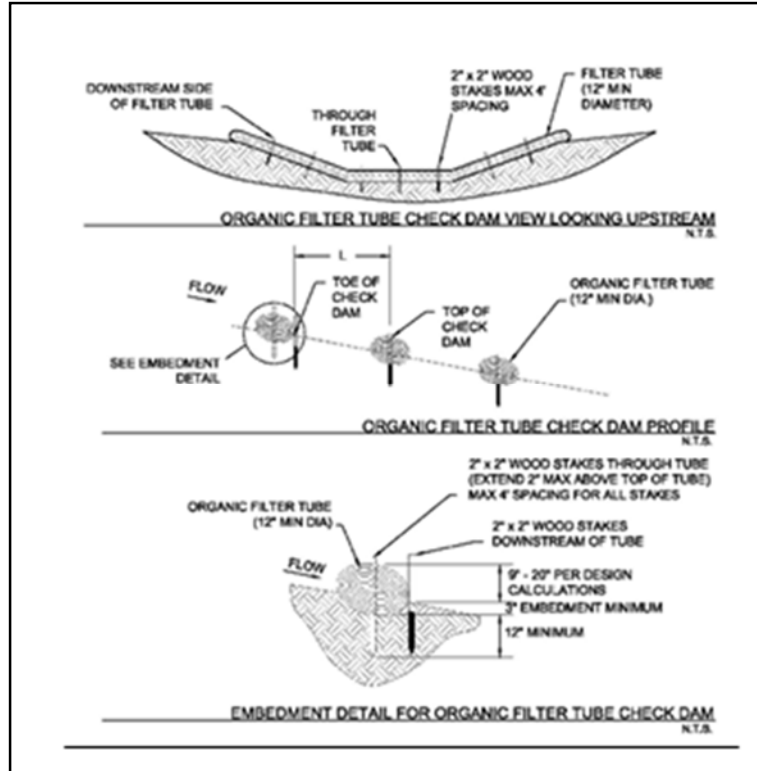

APPLICATION:

- ◆ Check dams are used in swales and drainage ditches (including those along linear projects such as roadways).
- ◆ They can also be used in short swales down a steep slope to reduce velocities.
- ◆ Check dams shall not be used in live stream channels.
- ◆ Check dams should be installed before the contributing drainage area is disturbed, so as to mitigate the effects on the swale from the increase in runoff.
- ◆ If the swale itself is graded as part of the construction activities, check dams are installed immediately upon completion of grading to control velocities in the swale until stabilization is completed.

INSTALLATION/USE PROCEDURE:

- ◆ Dam height should be between 9 and 36 inches and less than one-third the depth of the channel
- ◆ Dams should be spaced such that the top of the downstream dam is at the same elevation as the toe of the upstream dam. On channel grades flatter than 0.4 percent, check dams should be placed at a distance that allows small pools to form between each check dam.
- ◆ The top of the side of the check dam shall be a minimum of 12 inches higher than the middle of the dam. In addition, the side of the dams shall be embedded a minimum of 18 inches into the side of the drainage ditch, swale or channel to minimize the potential for flows to erode around the side of the dam.
- ◆ Check dams should be used in conjunction with other sediment reduction techniques prior to releasing flow offsite.

- ◆ Use geotextile fabric (of appropriate tensile strength, puncture rating and apparent opening size) under check dams of 12 inches in height or greater.
- ◆ Loose soil, wood chips, compost, and other floatable materials that are transportable during runoff should not be used to construct a check dam.

ALTERNATIVE DESIGN

- ◆ See “Rock Check Dam for Channels”

OPERATOR BMP MODIFICATION OR REPLACEMENT:

- ◆ Operator is invited to propose an alternative BMP or modify this preferred BMP. The proposed BMP must match or exceed performance requirements as this preferred BMP. Any deviations from this preferred BMP must be reviewed and accepted by the oversight authority.
- ◆ Submit BMP modifications or replacements to the oversight authority for review; including but not limited to; Proprietary system literature, modified illustrations, any operation procedures and maintenance adjustments, etc.

MAINTENANCE/MANAGEMENT:

- ◆ Inspect the check dam system each report period and after storm events.
- ◆ Remove silt when sediment accumulation reaches approximately 1/3 the height of the dam.
- ◆ Inspect for erosion beneath and around check dam (particularly where edge of the dam meets the side of the channel) and restore as needed each report period.
- ◆ If erosion continues to be a problem, modifications to the check dam or additional controls must be engineered.

PERFORMANCE:

- ◆ Check dam systems are intended to perform as engineered up to .25” of rain fall
- ◆ Check dams are performing as intended if the drainage channel they are protecting does not develop deep erosive gulley’s between dams and the dam itself is not being undercut by erosion or eroded to either side of the dam.
- ◆ Due to the minimal sediment capture capability of check dams, good performance will include accumulations of sediment on the upstream side of dams between maintenance intervals.

It is considered a BMP failure when any of the following occur:

- ◆ System not installed per illustrated detail, system not maintained, or system damaged by construction operations.
- ◆ Erosion damage resulting in variance from detail dimensions.

REFERENCE:

U-CGP 2.2.11 – “Minimize erosion of constructed or natural site drainage feature channels and their embankments, outlets, adjacent streambanks, slopes, and downstream waters. Use erosion controls and velocity dissipation devices within and along the length of any constructed or natural site drainage feature channel and at any outlet to slow down runoff and minimize erosion.”

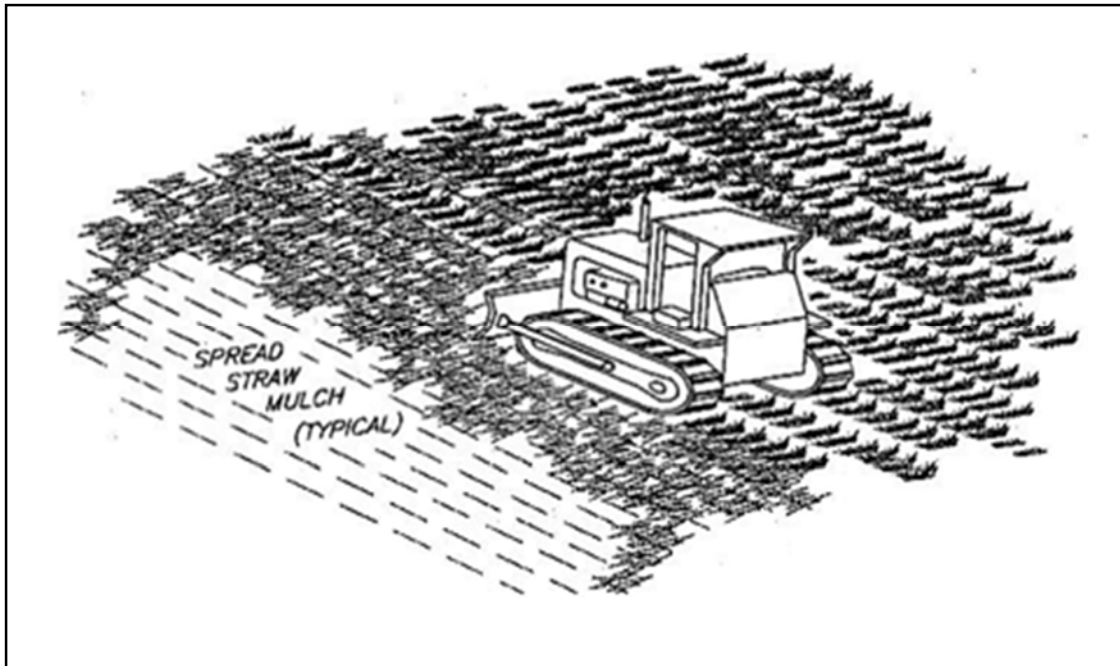

DESCRIPTION:

Applying materials such as vinyl, asphalt, plastics, or rubber on an unprotected slope to temporarily stabilize the slope.

APPLICATIONS:

- ◆ As a tacking agent to aid the stabilization of mulches (where matting is not used).
- ◆ As a short-term alternative in areas where temporary seeding practices cannot be used because of seasonal condition or climate.
- ◆ On steep and rocky slopes where neither mechanical methods or mulches and protective netting can be effectively applied.

INSTALLATION/APPLICATION CRITERIA:

- ◆ The application rates and procedures recommended by the manufacturer of a chemical stabilization product should be followed to prevent the products from forming ponds and from creating large areas where moisture cannot get through.
- ◆ For permanent application, chemical mulches (when used with seed and mulch) should be applied over wood fiber or straw mulch.

LIMITATIONS:

- ◆ Chemical mulches can create impervious surfaces and impact water quality if not properly applied.
- ◆ Some products may not be suitable for use near live streams.

MAINTENANCE:

- ◆ Inspect at regular intervals and after each runoff-producing storm event.
- ◆ Replace chemical mulch as needed to ensure adequate level of coverage.

APPLICATION:

- ◆ Use Chemical/Hazardous Materials Management BMP when chemicals or hazardous materials are used or stored at the construction site.

INSTALLATION/USE PROCEDURES:

- ◆ Store chemicals and/or other hazardous materials in sealed, clearly labeled containers.
- ◆ Safety Data Sheets (SDS) specific to each chemical must be accessible on site.
- ◆ When chemicals/hazardous materials are not in use, store materials in such a way that they are not exposed to stormwater or runoff. (covered and off the ground)
- ◆ Storage and use areas must be located away from waters of the state, sensitive areas, and storm water conveyance systems
- ◆ Submit illustration or detail for secondary containment system when secondary containment and/or cover is required (containers more than 55 gallons); such as drip pan, spill containment pallets, or spill berm with impermeable liner.
- ◆ Attach a spill plan and provide a spill kit in good working condition sufficient to address small spills and protect water quality.

OPERATOR BMP MODIFICATION OR REPLACEMENT:

- ◆ Operator is invited to propose an alternative BMP or modify this preferred BMP. The proposed BMP must match or exceed performance requirements as this preferred BMP. Any deviations from this preferred BMP must be reviewed and accepted by the oversight authority.
- ◆ Submit BMP modifications or replacements to the oversight authority for review; including but not limited to; Proprietary system literature, modified illustrations, any operation procedures and maintenance adjustments, etc.

MAINTENANCE/MANAGEMENT:

- ◆ Train employees and subcontractors in chemical/hazardous materials BMPs.
- ◆ Regularly inspect the chemical storage area and the construction site for evidence of spills
- ◆ Spills must be properly cleaned up with dry clean-up methods only.
- ◆ For spills that occur on permeable surfaces, remove contaminated material before leaching occurs and dispose according to manufacturer's recommended method of disposal and in compliance with Federal, State, Tribal, and local requirements
- ◆ Large spills must be documented and reported according to Section 2.3.6 of the CGP.
- ◆ Keep ample supplies of spill cleanup materials on-site and perform any repairs necessary to contain chemicals appropriately immediately.
- ◆ Dispose of expired or used up hazardous materials in accordance with the manufacturer's recommended method of disposal and in compliance with Federal, State, Tribal, and local requirements.

PERFORMANCE:

- ◆ This BMP is expected to contain chemical/hazardous materials in such a way that it cannot pollute the environment.
- ◆ No pollutants are allowed to reach storm water conveyance systems or waters of the state.

REFERENCE:

- ◆ CGP2.3.3

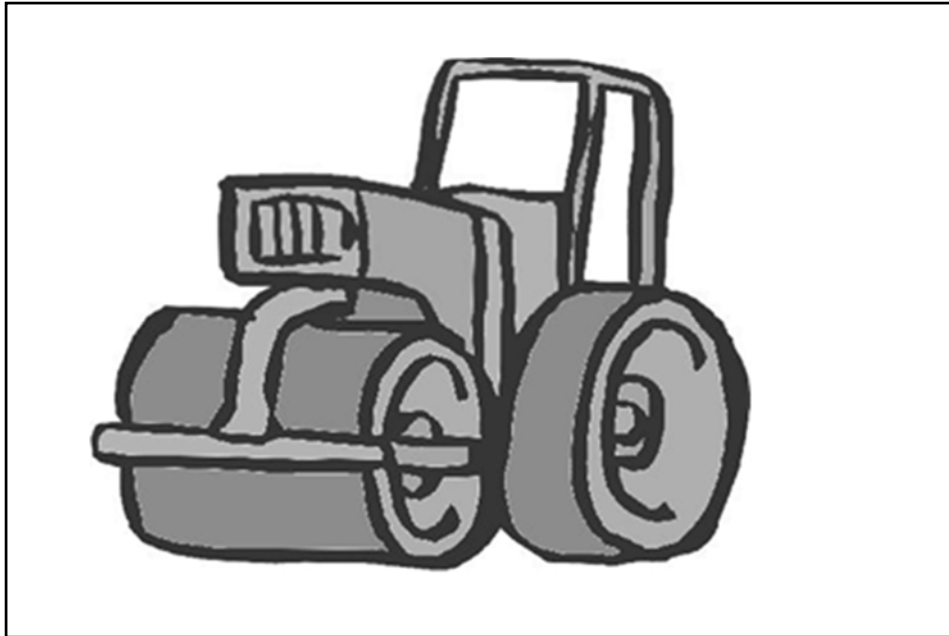
**DESCRIPTION:**

Use of rolling, tamping, or vibration to stabilize fill materials and control erosion by increasing the soil density. Increasing the density of soil improves soil strength, reduces long-term soil settlement, and provides resistance to erosion.

APPLICATIONS:

- ◆ Stabilize fill material placed around various structures.
- ◆ Improve soil in place as foundation support for roads, parking lots, and buildings.

INSTALLATION/APPLICATION CRITERIA:

- ◆ Make sure soil moisture content is at optimum levels.
- ◆ Use proper compaction equipment.
- ◆ Install sediment control and storm water management devices below compacted areas and runoff interceptor devices above these areas. Drainage from compacted areas must be carefully planned to protect adjacent uncompacted soils.
- ◆ The surface of compacted areas should be scarified and seeded or mulched and seeded to increase the effectiveness of compaction.

LIMITATIONS:

- ◆ Compaction tends to increase runoff.
- ◆ Over-compaction will hamper revegetation efforts.

MAINTENANCE:

- ◆ No maintenance required.

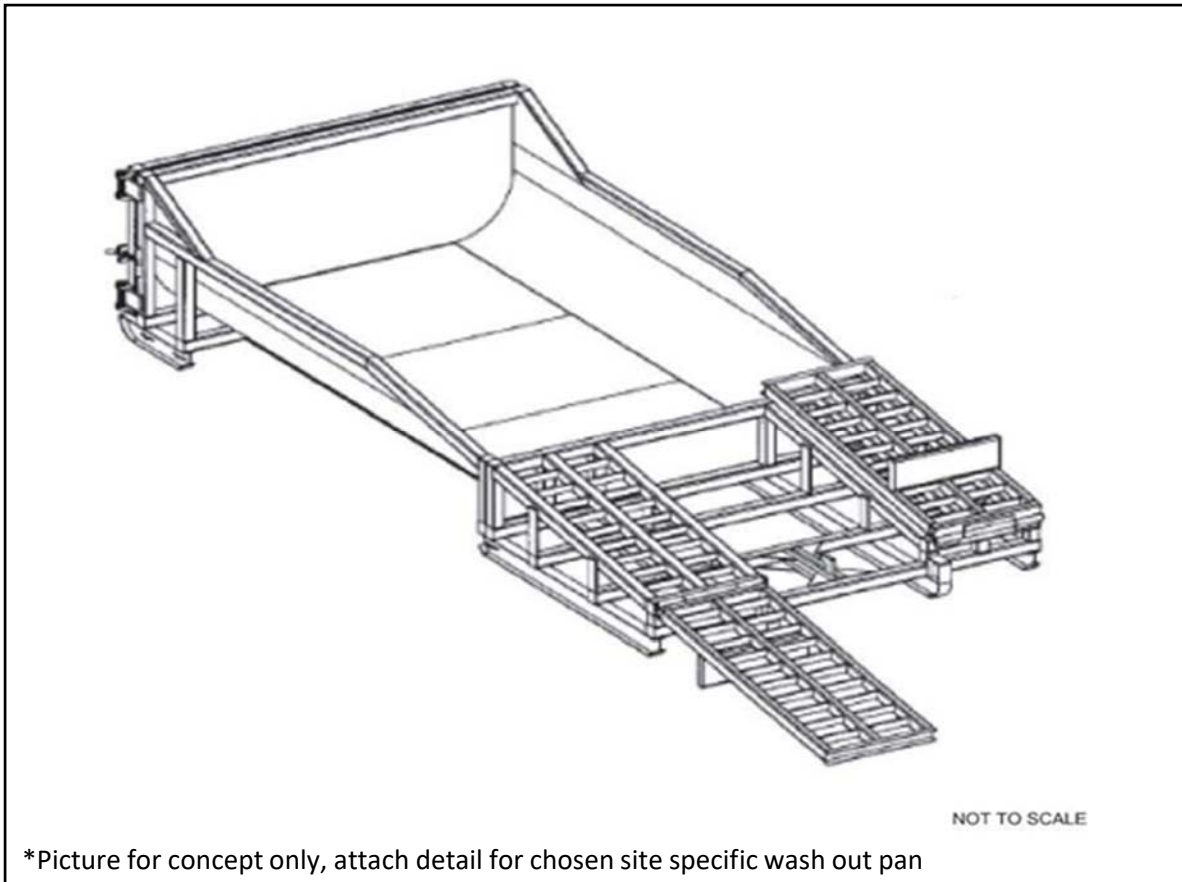

APPLICATION:

- ◆ Concrete waste management is necessary on construction sites when:
- ◆ Concrete, grout, or mortar is used as a construction material.
- ◆ Concrete truck drums, chutes, and hoses, or other concrete equipment (e.g. hand tools, screeds, shovels, rakes, floats, trowels, and wheelbarrows) are washed on-site and it is not possible to dispose of all concrete wastewater and washout off-site (ready mix plant, etc.).
- ◆ Grout or mortar mixing stations are used.

INSTALLATION/USE PROCEDURES:

- ◆ Locate pans next to track-out or parking pad or provide its own anti-track-out system and area for driver chassis washing. Attach illustration with dimensions. Reference other track-out BMPs as needed to manage site conditions.
- ◆ Install a sign at each washout location and identify on the SWPPP BMP map.
- ◆ Locate washout facilities a minimum of 50 feet from sensitive areas such as storm drains, open ditches, water bodies, wetlands, or where an infiltration feature will be installed. Protect downstream inlets.
- ◆ When the minimum distance from sensitive areas is not practicable, provide secondary containment and attach containment system specifications to this BMP.

- ◆ Empty excess concrete onto the ground near the pour site until only liquid cement remains on tools and equipment.
- ◆ Wash cement off of the chute, pump equipment, and tools directly into the washout pan.
- ◆ Ensure concrete truck operators and concrete transport/disposal service providers have the necessary support to protect water quality.
- ◆ The operator is expected to modify the concrete waste management system, location and capacity when necessary as site conditions and operations warrant.
- ◆ The operator shall oversee and enforce concrete waste management procedures.
- ◆ Educate employees, concrete suppliers, and subcontractors of these concrete waste management requirements. Discuss the concrete management techniques with concrete suppliers before any deliveries are made.
- ◆ Incorporate requirements for concrete waste management into concrete supplier and subcontractor agreements.

OPERATOR BMP MODIFICATION OR REPLACEMENT:

- ◆ Operator is invited to propose an alternative BMP or modify this preferred BMP. The proposed BMP must match or exceed performance requirements as this preferred BMP. Any deviations from this preferred BMP must be reviewed and accepted by the oversight authority.
- ◆ Submit BMP modifications or replacements to the oversight authority for review; including but not limited to; Proprietary system literature, modified illustrations, any operations procedures and maintenance adjustments, etc.

MAINTENANCE/MANAGEMENT:

- ◆ Washouts must be maintained to provide adequate holding capacity with one foot of freeboard.
- ◆ Washout pan must be cleaned, or additional pans provided and ready for use once the concrete washout pan is 70% full.
- ◆ Maintenance includes removal and disposal of hardened concrete and excess liquid or slurry.
- ◆ Excess liquid and slurry shall be pumped or evaporated prior to removal of solids.
 - Attach method of liquid disposal including licensed dumping location.
- ◆ Dispose of all materials in conformance with applicable federal, state, and local regulations. **Do not discharge liquid or slurry to waterways, storm drains or directly onto ground.**
- ◆ Inspect washout pans at least weekly, and before and after each concrete operation. During extended wet weather conditions, ensure track out is not occurring.
 - Check overall condition and performance.
 - Check remaining capacity (% full)
 - If using prefabricated pan containers, check for leaks.
- ◆ Damaged or leaking washout facilities shall be addressed immediately.

PERFORMANCE:

- ◆ Pans must be water-tight with sufficient volume plus 1 foot freeboard to meet concrete washout needs in between maintenance/service intervals. Attach concrete waste volume calculations and identify the number washout pans required.
- ◆ The performance expected of a wash out pan is to contain all pollutants associated with washout of concrete, slurry, mortar, and other products with no discharge at any time during operations.

It is considered a concrete waste management failure when any of the following occur:

- ◆ There are leaks, overflows, or spills of concrete waste. The discharge of concrete washout waters is classified as a "Prohibited Discharge"
- ◆ Track-out associated with the concrete washout BMP operation.

REFERENCE:

- CGP 2.3.4
- CPP 2.9.1

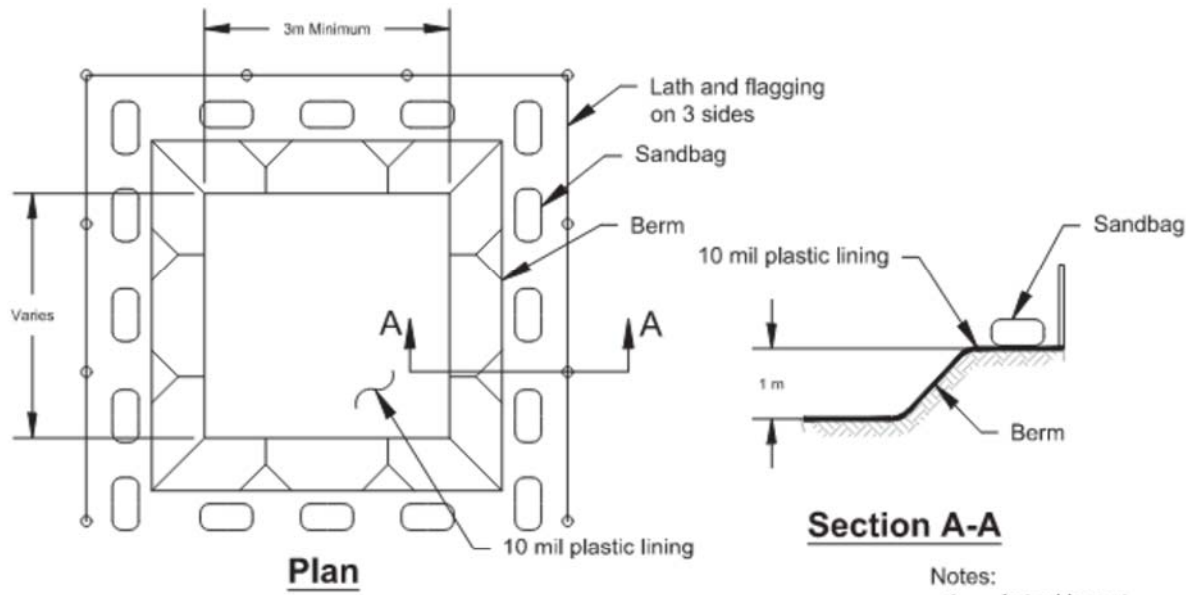

Type "Below Grade"

- Notes:
1. Actual layout determined in the field.
 2. A concrete washout sign shall be installed within 10 m of the temporary concrete washout facility.

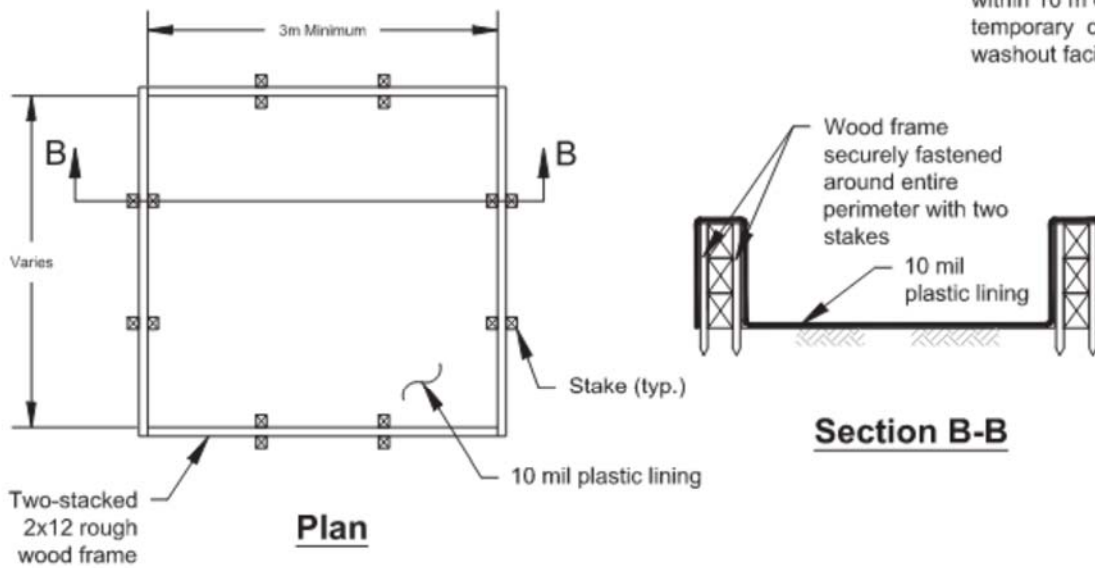

Type "Above Grade" with Wood Planks

NOT TO SCALE

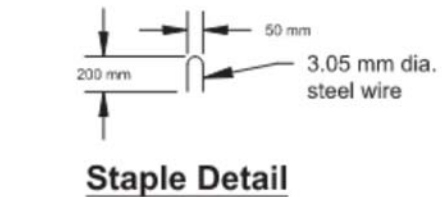
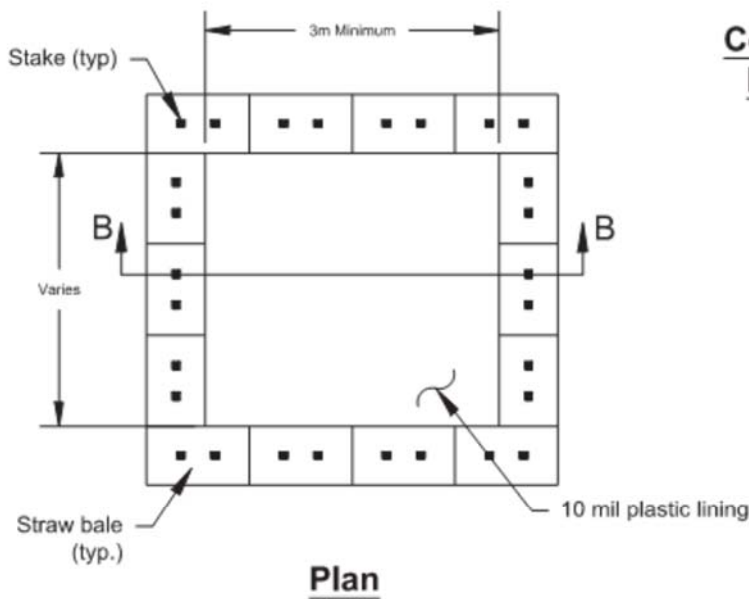
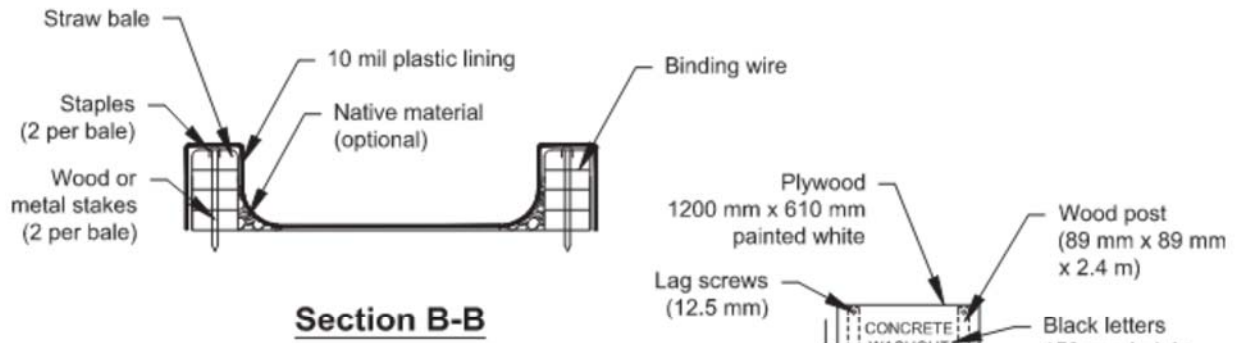

- Notes:
1. Actual layout determined in the field.
 2. The concrete washout sign shall be installed within 10 m of the temporary concrete washout facility.

Type "Above Grade" with Straw Bales

NOT TO SCALE

APPLICATION:

- ◆ Concrete waste management is necessary on construction sites when:
- ◆ Concrete, grout, or mortar is used as a construction material.
- ◆ Concrete truck drums, chutes, and hoses, or other concrete equipment are washed on-site and it is not possible to dispose of all concrete wastewater and washout off-site (ready mix plant, etc.).
- ◆ Grout or mortar mixing stations are used.
- ◆ The washout facility shall be watertight and impermeable.
- ◆ The washout facility may be a self-installed structure or a pre-fabricated structure
- ◆ For self-installed washout structures, the lining material shall be a minimum of 10-mil polyethylene sheeting and must be free of holes, tears, or other defects that compromise the impermeability of the material. Liner materials shall be installed in accordance with manufacturer's recommendations.
 - No seams in the plastic are allowed at the bottom of the washout. The soil base shall be prepared free of rocks or other debris that may cause tears or holes in the plastic lining material.
- ◆ Washout facilities shall be constructed and maintained with sufficient quantity and volume to contain all liquid and concrete waste generated by washout operations.
- ◆ On large sites with extensive concrete work, multiple washouts may be needed to provide adequate capacity.
- ◆ Locate pans next to track-out or parking pad or provide its own anti-track-out system and area for driver chassis washing. Attach illustration with dimensions. Reference other track-out BMPs as needed to manage site conditions.
- ◆ A sign shall be installed at each washout location.
- ◆ Install the washout at the location specified in the SWPPP.
- ◆ Locate washout facilities a minimum of 50 feet from sensitive areas such as storm drains, open ditches, water bodies, wetlands, or where an infiltration feature will be installed. Protect downstream inlets.
- ◆ When the minimum distance from sensitive areas is not practicable, provide secondary containment and attach containment system specifications to this BMP.
- ◆ Keep the washout areas away from other construction traffic and access areas to reduce the likelihood of accidental damage, spills, or tracking.
- ◆ Inspect and verify that concrete washout areas are in place prior to the commencement of concrete work.

OPERATOR BMP MODIFICATION OR REPLACEMENT:

- ◆ Operator is invited to propose an alternative BMP or modify this preferred BMP. The proposed
- ◆ BMP must match or exceed performance requirements as this preferred BMP. Any deviations from this preferred BMP must be reviewed and accepted by the oversight authority.
- ◆ Submit BMP modifications or replacements to the oversight authority for review; including but not limited to; Proprietary system literature, modified illustrations, any operation procedures and maintenance adjustments, etc.

MAINTENANCE/MANAGEMENT:

- ◆ When materials are removed from ground fixed concrete washout systems, build a new structure; or, if the previous structure is still intact, inspect for signs of weakening or

damage, and make any necessary repairs. Re-line the structure with new 10-mil polyethylene sheeting after each cleaning.

- ◆ Washouts must be maintained to provide adequate holding capacity with one foot of freeboard.
- ◆ Once the concrete washout system is 70% full, it is time to remove the existing waste material to allow further use or provide an additional washout facility.
- ◆ Maintenance includes removal and disposal of hardened concrete and excess liquid or slurry.
- ◆ Excess liquid and slurry shall be pumped or evaporated prior to removal of solids.
 - Attach method of liquid disposal including licensed dumping location.
- ◆ Dispose of all materials in conformance with applicable federal, state, and local regulations.
 - Do not discharge liquid or slurry to waterways, storm drains or directly onto ground.
- ◆ Inspect ground fixed concrete washout systems at least weekly, and before and after each concrete operation. During extended wet weather conditions, ensure track out is not occurring.
 - Check overall condition and performance.
 - Check remaining capacity (% full)
 - Check for leaks
- ◆ Damaged or leaking washout facilities shall be addressed immediately.
- ◆ When concrete washout areas are no longer required for the work, the hardened concrete and containment system shall be removed and disposed of at a licensed waste facility. Attach information of disposal facility. Where concrete is recycled attach recycling facility information.
- ◆ Holes, depressions, or other ground disturbances caused by the removal of concrete washout areas shall be backfilled, repaired, and stabilized to prevent erosion.

PERFORMANCE:

- ◆ The performance expected of a wash out pan is to contain all pollutants associated with washout of concrete, slurry, mortar, and other products with no discharge at any time during operations.

It is considered a concrete waste management failure when any of the following occur:

- ◆ There are rips, tears, or defects in the containment system
- ◆ Seepage overflows are observed or waste is outside of the containment system
- ◆ Track-out associated with the concrete washout BMP operation.

REFERENCE:

- ◆ CGP 2.3.4,
- ◆ CPP 2.4.5, 2.9.1

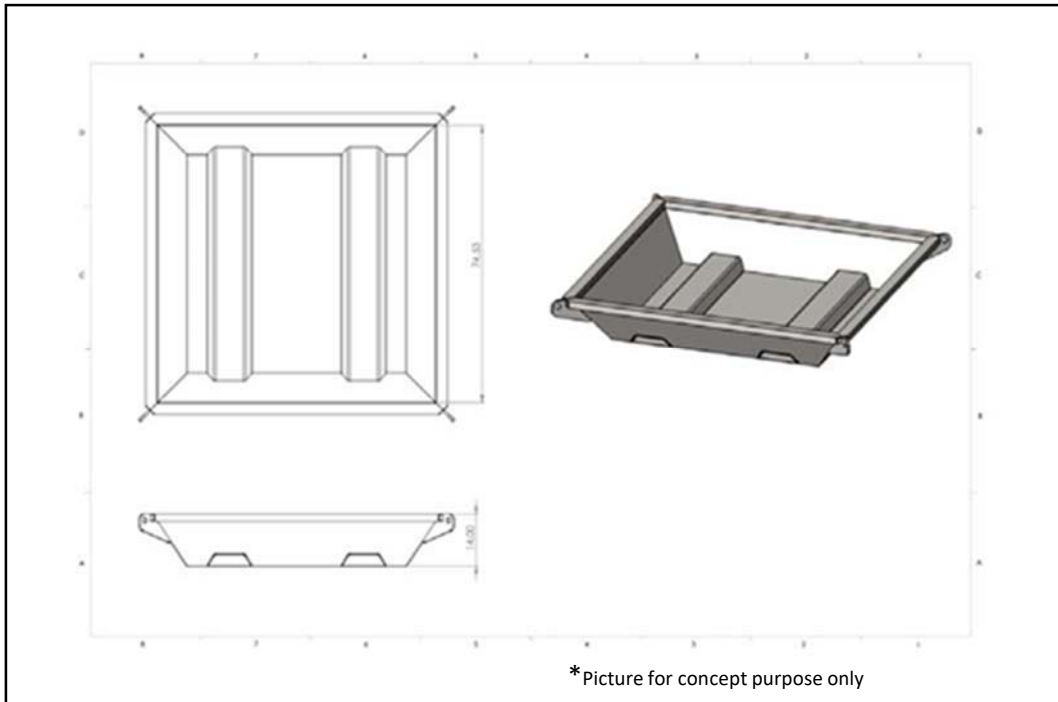

APPLICATION:

- ◆ Use for small pours only. Usually for single lot residential homes or other minor projects where the washout volume is small and using a standard proprietary concrete washout pan system is not feasible.

INSTALLATION/USE PROCEDURES:

- ◆ Small metal pan, plastic pools or equal portable watertight disposable container that can contain caustic materials. Attach dimensions of containers.
- ◆ Calculate concrete waste volume required. Attach calculations and identify the number of containment systems needed. Simply repeat this BMP for each day's concrete operation. Provide one additional container for redundancy.
- ◆ Maximize the capacity of the small containment system:
 - Empty excess concrete onto the ground near the pour site.
 - Wash cement off of the chute, pump equipment, and tools directly into the washout container.
- ◆ Place containers on a flat surface, near the track-out where there is enough room to wash the chassis and remove mud from the tires. Locate on the site BMP map.
- ◆ Containers are not allowed in roadway right of ways.
- ◆ Do not haul containers away until the waste concrete is set and all water has evaporated.
- ◆ Ensure the workforce is informed how to use your concrete management BMP.

OPERATOR BMP MODIFICATION OR REPLACEMENT:

- ◆ Operator is invited to propose an alternative BMP or modify this preferred BMP. The proposed BMP must match or exceed performance requirements as this preferred BMP. Any deviations from this preferred BMP must be reviewed and accepted by the oversight authority.
- ◆ Submit BMP modifications or replacements to the oversight authority for review; including but not limited to; Proprietary system literature, modified illustrations, any operation procedures and maintenance adjustments, etc.

MAINTENANCE/MANAGEMENT:

- ◆ Cover the containment system when not in use if a rain event is anticipated.
- ◆ Individual containers should no longer be used for washout once the volume capacity has reached 70% full. Utilize an additional container.
- ◆ This is a one-time disposable BMP, typical maintenance is not necessary. Any exposed concrete washing and disposal operations are considered a BMP failure because the operation was not adequately anticipated and implemented.
- ◆ When the daily concrete management operation is completed simply repeat this BMP.

PERFORMANCE:

It is considered a concrete waste management failure when any of the following occur:

- ◆ Washout container overflows.
- ◆ Containers are hauled away prior to concrete set up and when liquid was not completely evaporated.
- ◆ When track-out results from washout container inadequate placement.
- ◆ When supply truck chassis are being washed outside of the containment system.

REFERENCE:

- ◆ CGP 2.3.4
- ◆ CPP 2.4.5, 2.9.

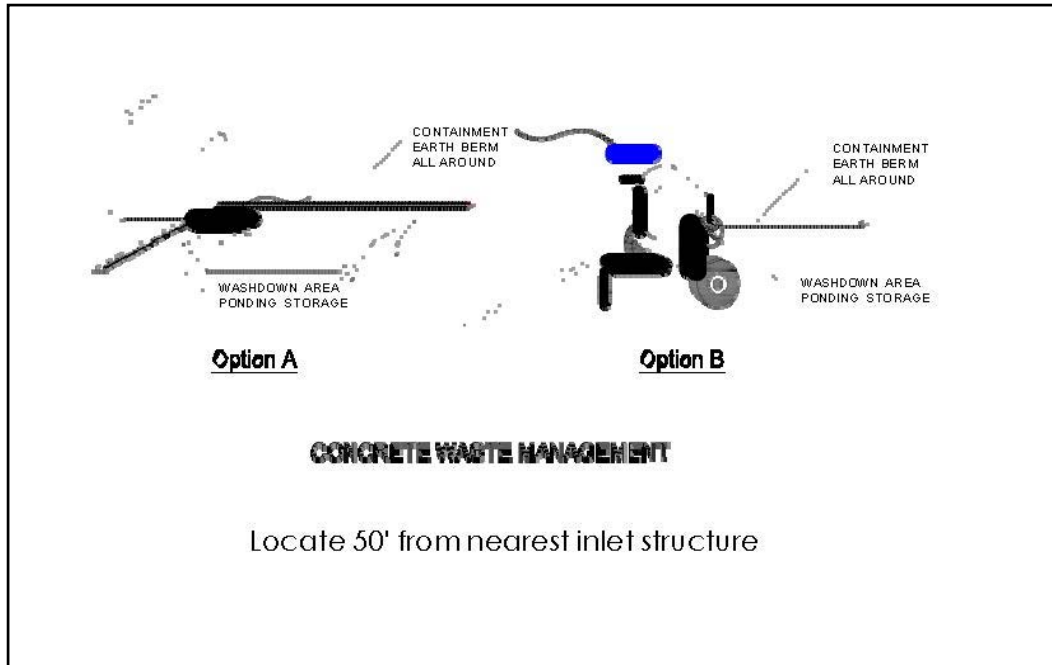

DESCRIPTION:

Prevent or reduce the discharge of pollutants to storm water from concrete waste by conducting washout off-site, performing on-site washout in a designated area, and training employees and subcontractors.

APPLICATION:

This technique is applicable to all types of sites.

INSTALLATION/APPLICATION CRITERIA:

- ◆ Store dry materials under cover, away from drainage areas.
- ◆ Minimize excess mixing of fresh concrete, mortar or cement on-site.
- ◆ Perform washout of concrete trucks off-site or in designated areas only.
- ◆ Do not wash out concrete trucks into storm drains, open ditches, streets, or streams.
- ◆ Do not allow excess concrete to be dumped on-site, except in designated areas.
- ◆ When washing concrete to remove fine particles and expose the aggregate, avoid creating runoff by draining the water within a bermed or level area. (6" tall by 6" wide).
- ◆ Train employees and subcontractors in proper concrete waste management.

LIMITATIONS:

- ◆ Off-site washout of concrete wastes may not always be possible.

MAINTENANCE:

- ◆ Inspect subcontractors to ensure that concrete wastes are being properly managed.
- ◆ If using a temporary pit, dispose hardened concrete on a regular basis.

APPLICATION:

- Projects where groundwater is anticipated or other dewatering operation volumes would exceed available space for onsite retention.
- Project where pressure system and waterline commissioning is necessary
- Projects where groundwater warranted dewatering operations are anticipated.

OPERATION PROCEDURE:

- Provide dewatering operation location(s) on BMP map.
- Attach a copy of the DEQ Dewatering Permit to this BMP.
- Attach a copy of all permit required inspection, monitoring requirements, operator prepared BMPs or proprietary systems and chemical treatment methods.
- Ensure the workforce is informed of the DEQ permit dewatering BMP requirements.

OPERATOR BMP MODIFICATION OR REPLACEMENT:

- Operator is invited to propose an alternative BMP or modify this preferred BMP. The proposed BMP must match or exceed performance requirements as this preferred BMP. Any deviations from this preferred BMP must be reviewed and accepted by the oversight authority.
- Submit BMP modifications or replacements to the oversight authority for review; including but not limited to; Proprietary system literature, modified illustrations, any operation procedures and maintenance adjustments, etc.

MAINTENANCE/MANAGEMENT:

- Ensure proprietary system, inspection, monitoring maintenance and application methods are followed.
- Train workforce when non-containment is recognized.

PERFORMANCE:

- Any uncontained dewatering volume constitutes BMP failure.
- Any DEQ Dewatering Permit non-compliance.

REFERENCE:

- CGP 1.2.2, 1.2.4, 2.3.7, 7.3.4
- CPP 2.2.3

APPLICATION:

- Project where waterline system commissioning is necessary
- A DEQ Dewatering permit is not required when full retention is provided onsite. Note, groundwater warranted dewatering operations usually do not qualify for a DEQ Dewatering Permit waiver. The exposure period and amount of groundwater results in uncertain volume calculations.

INSTALLATION/USE PROCEDURES:

- Provide a retention location on BMP map.
- Provide a simple detail of retention pond and operation volume necessary for full retention of anticipated dewatering volume. Attached copy of volume calculations to this BMP.
- Ensure the workforce is informed of the CGP dewatering BMP requirements.

OPERATOR BMP MODIFICATION OR REPLACEMENT:

- Operator is invited to propose an alternative BMP or modify this preferred BMP. The proposed BMP must match or exceed performance requirements as this preferred BMP. Any deviations from this preferred BMP must be reviewed and accepted by the oversight authority.
- Submit BMP modifications or replacements to the oversight authority for review; including but not limited to; Proprietary system literature, modified illustrations, any operation procedures and maintenance adjustments, etc.

MAINTENANCE/MANAGEMENT:

- Inspect following dewatering operation and ensure volume exists for any subsequent dewatering operations.
- Train workforce when non-containment is recognized.

PERFORMANCE:

- Any uncontained dewatering volume constitutes BMP failure.

REFERENCE:

- CGP 1.2.2, 1.2.4, 2.3.7, 7.3.4
- CPP 1.2.4, 2.2.7

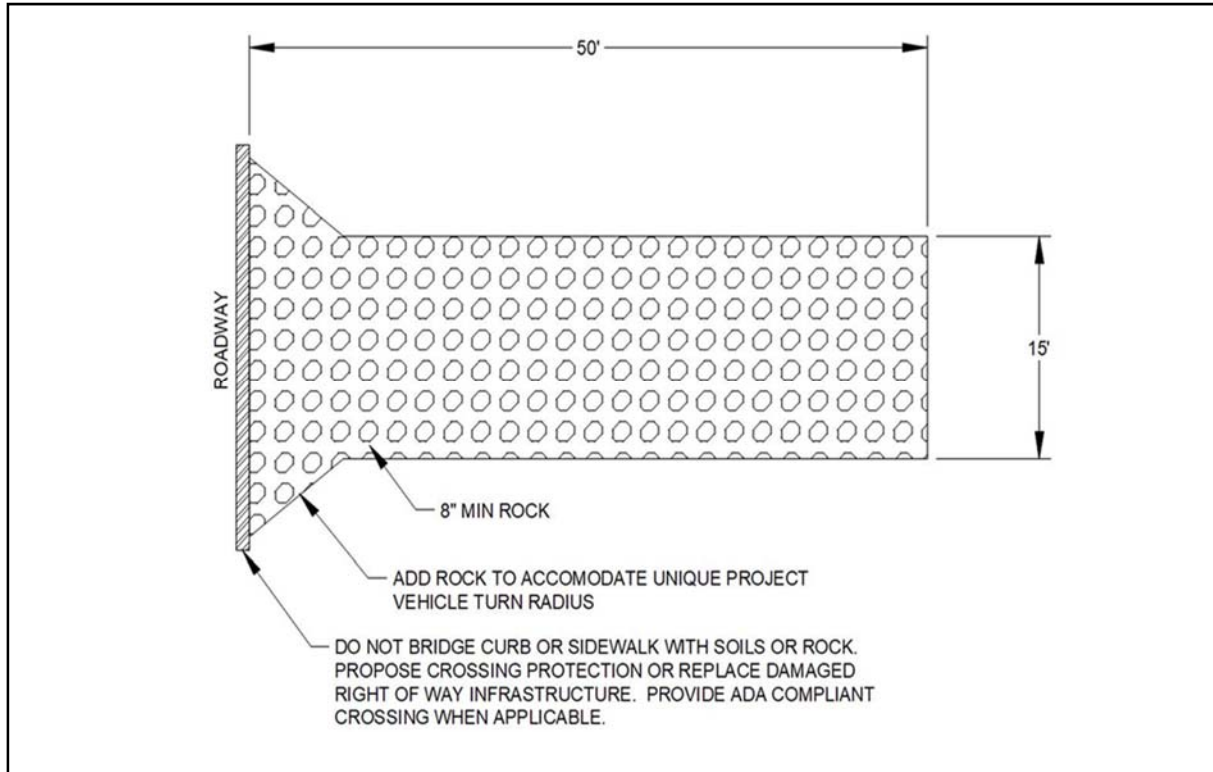

DESCRIPTION:

A stabilized pad of crushed stone located where construction traffic enters or leaves the site from or to paved surface.

APPLICATION:

- ◆ Use this BMP when vehicles and equipment operations require ingress or egress from the project property to decrease the amount of debris leaving the site via vehicle tracking.
- ◆ Particularly applicable in wet conditions in which sediment sticks more easily to tires/tracks.

INSTALLATION/APPLICATION CRITERIA:

- ◆ Determine the ingress/egress location(s) allowed by the oversight authority and show them on the site plan.
- ◆ Use 8" rock for the track out pad at a minimum depth of 8" and use dimensions described in the illustration above.
- ◆ Workforce and subcontractors must utilize the track out pad when leaving the construction site.
- ◆ Move vehicles forward and in reverse until mud is removed from tires.
- ◆ Stop, for rocks wedged in dual tires and remove any unremoved mud and wedged rocks.
- ◆ Ensure the workforce is trained regarding track-out BMP requirements.
- ◆ Use of Sweeping BMP is still usually necessary at the end of the day at minimum.

OPERATOR BMP MODIFICATION OR REPLACEMENT:

- ◆ Operator is invited to propose an alternative BMP or modify this preferred BMP. The proposed BMP must match or exceed performance requirements as this preferred BMP. Any deviations from this preferred BMP must be reviewed and accepted by the oversight authority.
- ◆ Submit BMP modifications or replacements to the oversight authority for review; including but not limited to; Proprietary system literature, modified illustrations, any operation procedures and maintenance adjustments, etc.

MAINTENANCE/MANAGEMENT:

- ◆ Rake, refresh or wash rock as necessary when space between rocks is inundated with mud.
- ◆ Add, extend or replace rock as necessary to achieve performance criteria results.
- ◆ Train workforce when BMP improper use is recognized.
- ◆ When sediment, rock, or gravel track out occurs due to BMP failure or misuse, debris must be removed from roadways according to the CGP criteria.

Street clean-up operations are separate from this Rock Track Out Pad BMP, but necessary to address unacceptable track out that may occur.

PERFORMANCE:

- ◆ Slick conditions, slurry, mud chunks, rocks, gravel, water quality risk and driver hazards constitute BMP failure and require immediate sufficient action.
- ◆ Light tracking is expected and requires regular maintenance but not usually immediate action. Light tracking is defined as minor residual dirt that can't be picked up by a square nose shovel.

Remove/sweep prior to unsafe and wet conditions or end of workday, whichever is first.

PERFORMANCE:

- ◆ CGP 2.2.4, 5.1, 5.2.1
- ◆ CPP 2.4.1

**DESCRIPTION:**

Reusable Composite Track-out Control Systems are designed to be used as a temporary construction entrance which provides site access while minimizing sediment leaving the site. The top surface of the mats are designed with geometric pattern formed in the shape of pyramids. These mats are unidirectional and are meant to have the staggered pyramids in the direction of travel. Individual mats are connected together with hardware to form various configurations to fit your jobsite.

APPLICATIONS:

- ◆ Use this BMP when vehicles and equipment operations require egress from the project property to decrease the amount of debris leaving the site via vehicle tracking.
- ◆ Particularly applicable in wet conditions in which sediment sticks more easily to tires/tracks.
- ◆ Reusable Track-out mats are used to fit the construction site needs and can be used in conjunction with other media/devices to eliminate track-out controls.
- ◆ Installation is typically faster and simple compared to other track-out control methods.

INSTALLATION/APPLICATION CRITERIA:

- ◆ Site evaluation to determine the proper layout of the Track-out Control System (TCS) based site conditions and the sites ingress/egress location(s) shown on the site plan.
- ◆ Trucks and Heavy Equipment must utilize the track out pad when leaving the construction site.
- ◆ Move vehicles forward and in reverse until mud is removed from tires.

LIMITATIONS:

- ◆ May require additional controls or maintenance once mats are at capacity of sedimentation.
- ◆ May require controls for surface storm water runoff.

- ◆ Will need frequent inspection for damage and secure placement of mats/boards for proper use.
- ◆ Site conditions will dictate design as need.

MAINTENANCE:

- ◆ Inspect routinely for damage and assess the effectiveness of the BMP.
- ◆ Remove aggregate, separate, and dispose of sediment if construction entrance/exit is clogged with sediment or as directed by the manufactures spec sheet.
- ◆ Can utilize mechanical broom, street sweepers or pressure washing to remove sediment and debris deposits from mats/boards, as long as it doesn't affect local authority storm drain systems.

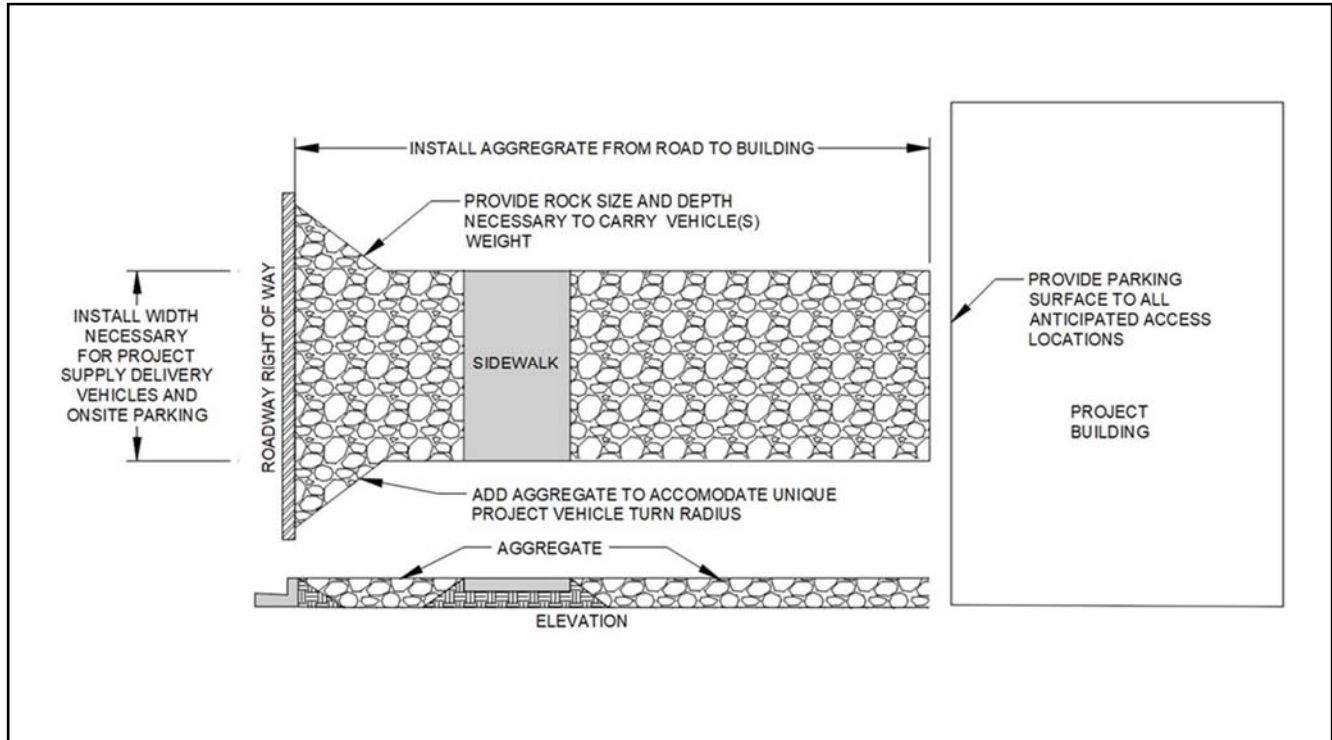

APPLICATION

- ◆ Use a parking pad for supply delivery vehicles, tool drop off and onsite project parking etc.
- ◆ Use this BMP to *prevent* mud from sticking to tires. This BMP will not remove mud sticking to tires.

INSTALLATION/USE PROCEDURES

- ◆ Determine where supplies and tools need to be delivered or dropped off and show the delivery area on the site plan. Coordinate with oversight authority for any prohibited access locations.
- ◆ Do not drive beyond the parking pad.
- ◆ Size pad to accommodate project supply vehicles and any necessary onsite parking. Attach illustration of specific dimensions for the parking pad and gravel/rock specific to the project needs with this BMP detail.
- ◆ Ensure the workforce is trained regarding proper use and maintenance of the parking/delivery pad.

OPERATOR BMP MODIFICATION OR REPLACEMENT

- ◆ Operator is invited to propose an alternative BMP or modify this preferred BMP. The proposed BMP must match or exceed performance requirements as this preferred BMP. Any deviations from this preferred BMP must be reviewed and accepted by the oversight authority.
- ◆ Submit BMP modifications or replacements to the oversight authority for review; including but not limited to; Proprietary system literature, modified illustrations, any operation procedures and maintenance adjustments, etc.

MAINTENANCE/MANAGEMENT

- ◆ Refresh parking/access pad as necessary when BMP is not effective at preventing mud from sticking to tires.
- ◆ Add, extend or replace rock as necessary to achieve performance criteria results.
- ◆ Train workforce when BMP improper use is recognized.
- ◆ When sediment, rock, or gravel track out occurs due to BMP failure or misuse, debris must be removed from roadways according to the CGP criteria.
 - Street clean-up operations are separate from this Parking Pad BMP, but necessary to address unacceptable track out that may occur.

◆ PERFORMANCE

- ◆ The parking pad and supplier access gravel pad is expected to reduce vehicle contact with exposed sediment on site.
- ◆ In addition, it also acts as a visual marker for suppliers to know where to make deliveries, increasing work site operation efficiency.
- ◆ Slick conditions, slurry, mud chunks, rocks, gravel, water quality risk and driver hazards constitute BMP failure and require immediate sufficient action.

REFERENCE:

- ◆ CGP 2.2.4, 5.1, 5.2.1
- ◆ CPP 2.4.1



DESCRIPTION:

Construction sequencing is a specified work schedule that coordinates the timing of land-disturbing activities and the installation of erosion and sediment control measures. Construction site phasing involves disturbing only part of a site at a time to prevent erosion from dormant parts. Grading activities and construction are completed and soils are effectively stabilized on one part of the site before grading and construction commence at another part.

APPLICATIONS:

- ◆ Sequencing can be used to plan earthwork and erosion and sediment control activities at sites where land disturbances might affect water quality in a receiving waterbody

INSTALLATION/APPLICATION CRITERIA:

Sequencing schedules should include the following Design and Installation Criteria:

- ◆ The erosion & sediment control practices that are to be installed
- ◆ Principal development activities
 - Which measures should be installed before other activities are started
 - Compatibility with the general contract construction schedule

LIMITATIONS:

- ◆ Weather and other unpredictable variables might affect sequence schedules. However, the erosion and sediment control plan should plainly state the proposed schedule and a protocol of making changes due to unforeseen problems.

MAINTENANCE:

- ◆ Follow the construction sequence throughout the project and modify the written plan before any changes in construction activities are executed. Update the plan if a site inspection indicates the need for additional erosion and sediment control.

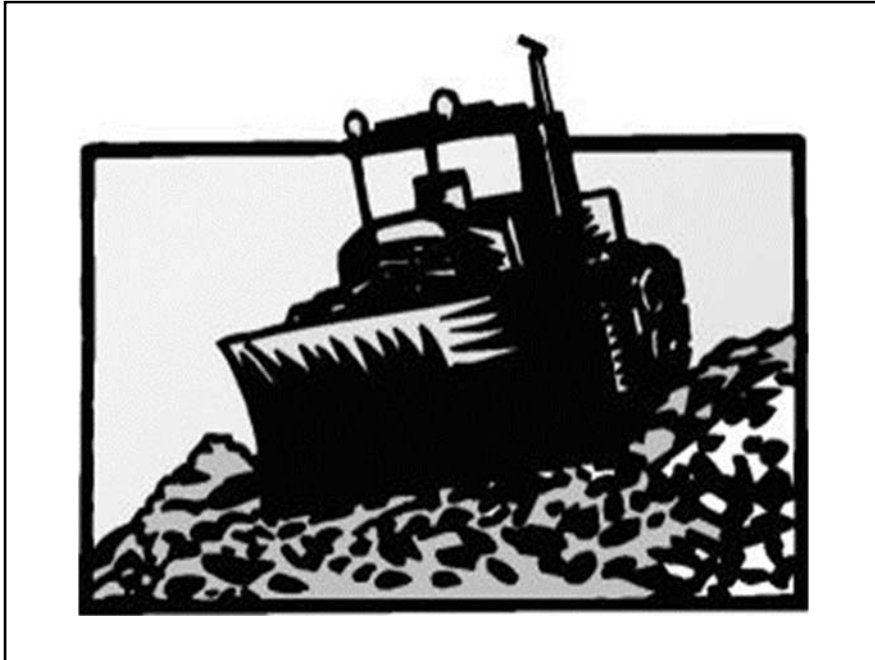

DESCRIPTION:

Prevent or reduce the discharge of pollutants to stormwater from contaminated or erodible surface areas by leaving as much vegetation on-site as possible, minimizing soil exposure time, stabilizing exposed soils, and preventing stormwater runoff and runoff.

APPLICATIONS:

- ◆ This BMP addresses soils which are not so contaminated as to exceed criteria but the soil is eroding and carrying pollutants off in the stormwater.

INSTALLATION/APPLICATION CRITERIA:

Contaminated or erodible surface areas can be controlled by:

- ◆ Preservation of natural vegetation, re-vegetation, chemical stabilization, removal of contaminated soils or geosynthetics.

LIMITATIONS:

Disadvantages of preserving natural vegetation or re-vegetating include:

- ◆ Requires substantial planning to preserve and maintain the existing vegetation.
- ◆ May not be cost-effective with high land costs.
- ◆ Lack of rainfall and/or poor soils may limit the success of re-vegetated areas.
- ◆ Disadvantages of chemical stabilization include:
 - Creation of impervious surfaces.
 - May cause harmful effects on water quality.
 - Is usually more expensive than vegetative cover.

MAINTENANCE:

- ◆ Maintenance should be minimal, except possibly if irrigation of vegetation is necessary.

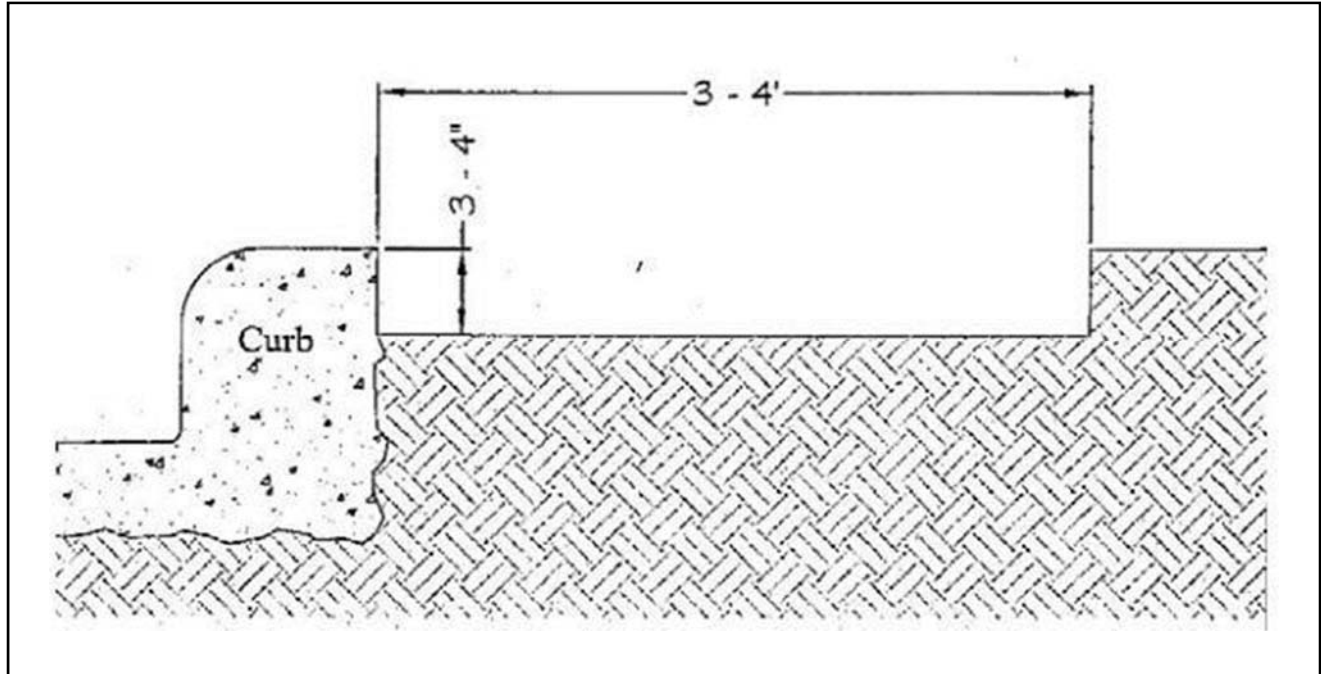

APPLICATION:

- ◆ Use at project boundaries in which final grading is sloped towards pavement or roadways to retain sediment.
- ◆ Only applicable when the site is sloped towards the curb such that runoff overtops the curb
- ◆ Particularly useful for residential sites when major earth disturbing activities have ceased and final site stabilization (landscape installation) is pending.

INSTALLATION/USE PROCEDURE:

- ◆ Excavate soil behind curb to a depth of 3-4 inches
- ◆ Extend the excavation 3-4 feet behind the curb to form a sediment trap
- ◆ Should not be installed on a slope that exceeds 5% as it may be ineffective and compromise the integrity of the curb
- ◆ Not suitable if underlying soil is expansive or collapsible, refer to the soils report.
- ◆ The sedimentation trap may be implemented behind a sidewalk instead of the curb
- ◆ The depth and width of the excavation may be increased if more sediment storage is necessary

OPERATOR BMP MODIFICATION OR REPLACEMENT:

- ◆ Operator is invited to propose an alternative BMP or modify this preferred BMP. The proposed BMP must match or exceed performance requirements as this preferred BMP. Any deviations from this preferred BMP must be reviewed and accepted by the oversight authority.
- ◆ Submit BMP modifications or replacements to the oversight authority for review; including but not limited to; Proprietary system literature, modified illustrations, any operation procedures and maintenance adjustments, etc.

MAINTENANCE/MANAGEMENT:

- ◆ Inspect at least once every seven calendar days, or once every 14 calendar days and within 24 hours of the occurrence of a storm event of 0.5 inches or greater.
- ◆ Remove accumulated sediment when it reaches ½ height of original excavation.

PERFORMANCE:

- ◆ Sediment, or sediment laden water overtopping the curb, leaving the site, and entering the roadway constitutes BMP failure and must be corrected immediately.

REFERENCE:

- ◆ CGP 2.2.3
- ◆ CPP 2.1.2

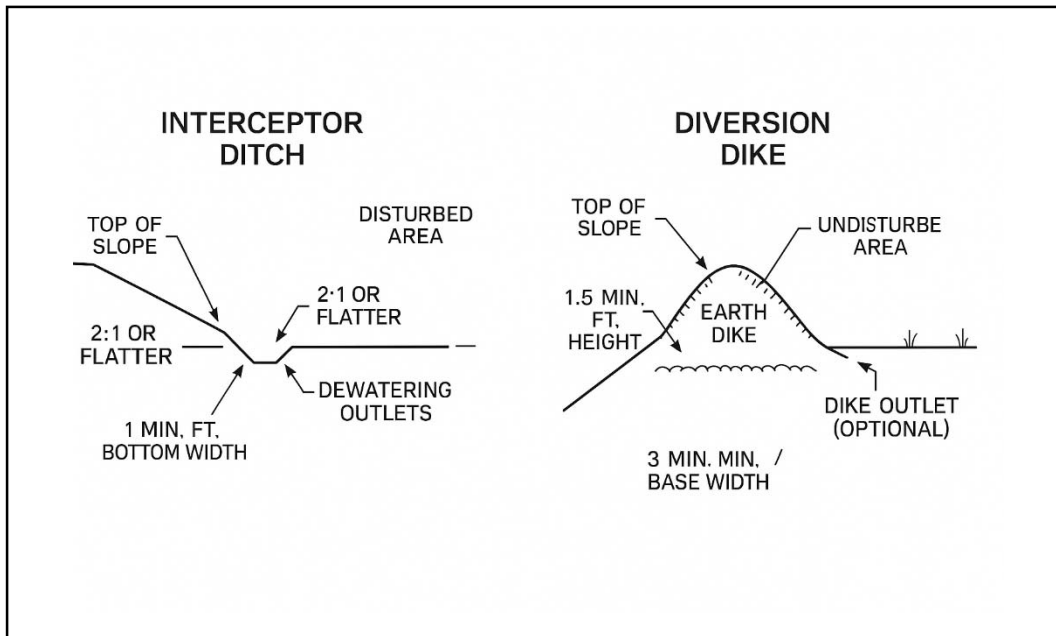

DESCRIPTION:

A temporary sediment barrier and storm runoff conveyance consisting of an excavation channel and compacted earth ridge.

APPLICATIONS:

- ◆ Construct along top of construction slope to intercept up-gradient runoff and convey around construction site.
- ◆ Construct along toe of construction to divert sediment laden runoff.
- ◆ Construct along midpoint of construction slope to intercept runoff and channel to controlled discharge point.
- ◆ Construct around base of soil stockpiles to capture sediment.
- ◆ Construct around perimeter of disturbed areas to capture sediment.

INSTALLATION/APPLICATION CRITERIA:

- ◆ Clear and grub area for dike construction.
- ◆ Excavate channel and place soil on down-gradient side.
- ◆ Shape and machine compact excavated soil to form ridge.
- ◆ Place erosion protection (riprap, mulch) at outlet.
- ◆ Stabilize channel and ridge as required with mulch, gravel, or vegetative cover.

LIMITATIONS:

- ◆ Recommended maximum drainage area of 5 acres.
- ◆ Recommended maximum side slopes of 2h:1v (50%).
- ◆ Recommended maximum slope on channel of 1%.

MAINTENANCE:

- ◆ Inspect immediately after any rainfall and at least daily during prolonged rainfall.
- ◆ Look for runoff breaching dike or eroding channel or side slopes.
- ◆ Check discharge point for erosion or bypassing of flows.
- ◆ Repair and stabilize as necessary.
- ◆ Inspect daily during vehicular activity on slope, check for and repair any traffic damage.



A truck equipped with a spray system can spray water throughout a construction site and prevent dust from being transported off-site.

DESCRIPTION:

Dust control measures are used to stabilize soil from wind erosion, and reduce dust by construction activities.

APPLICATIONS:

- ◆ Dust control is useful in any process area, loading and unloading area, material handling areas, and transfer areas where dust is generated. Street sweeping is limited to areas that are paved.

INSTALLATION/APPLICATION CRITERIA:

Contaminated or erodible surface areas can be controlled by:

- ◆ Mechanical dust collection systems are designed according to the size of dust particles and the amount of air to be processed. Manufacturers' recommendations should be followed for installation (as well as the design of the equipment).
- ◆ Two kinds of street sweepers are common: brush and vacuum. Vacuum sweepers are more efficient and work best when the area is dry.
- ◆ Mechanical equipment should be operated according to the manufacturers' recommendations and should be inspected regularly.

LIMITATIONS:

- ◆ Generally more expensive than manual systems.
- ◆ May be impossible to maintain by plant personnel (the more elaborate equipment).
- ◆ Labor and equipment intensive and may not be effective for all pollutants (street sweepers).

MAINTENANCE:

- ◆ If water sprayers are used, dust-contaminated waters should be collected and taken for treatment.
- ◆ Areas will probably need to be resprayed to keep dust from spreading.

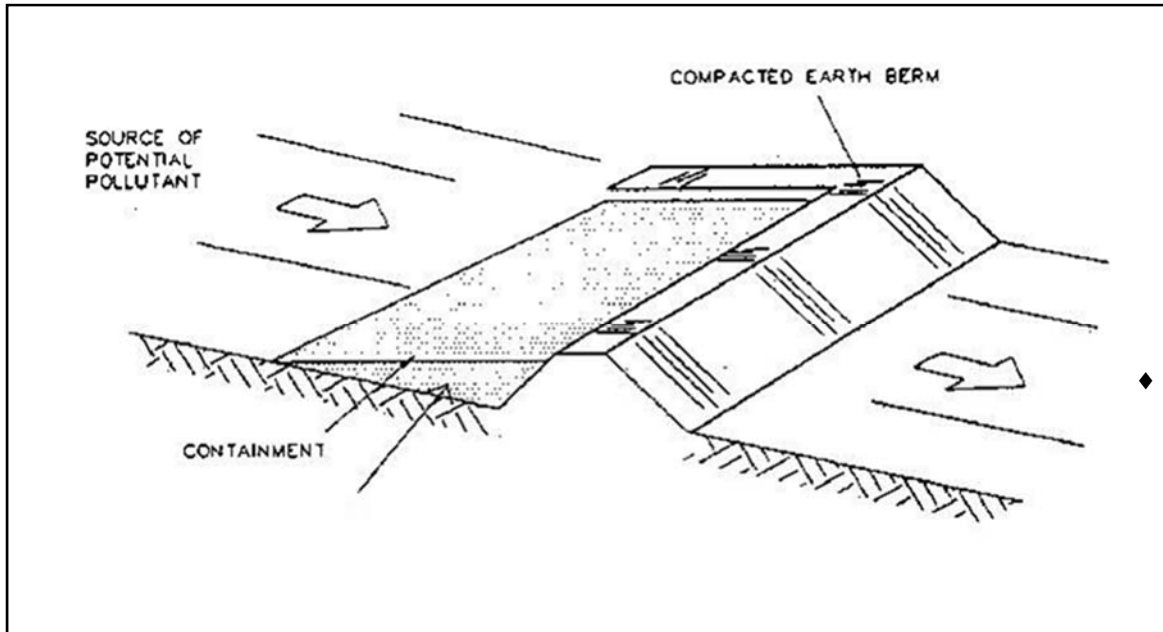

DESCRIPTION:

A temporary containment control constructed of compacted soil.

APPLICATION:

- ◆ Construct around waste and materials storage area.
- ◆ Construct around staging and maintenance areas.
- ◆ Construct around vehicle parking and servicing areas.

INSTALLATION/APPLICATION CRITERIA:

- ◆ Construct an earthen berm downhill of the area to be controlled. The berm should surround fueling facilities and maintenance areas on three sides to provide containment.
- ◆ Berm needs to be a minimum of 1 foot tall by 1 foot wide and be compacted by earth moving equipment.

LIMITATIONS:

- ◆ Not effective on steep slopes.
- ◆ Limits access to controlled area.
- ◆ Personnel need to quickly respond to spills with remedial actions.

MAINTENANCE:

- ◆ Observe daily for any non-stormwater discharge.
- ◆ Look for runoff bypassing ends of berms or undercutting berms.
- ◆ Repair or replace damaged areas of the berm and remove accumulated sediment.
- ◆ Recompect soil around berm as necessary to prevent erosion.

REFERENCE:

CGP 2.2.11
CPP 2.3

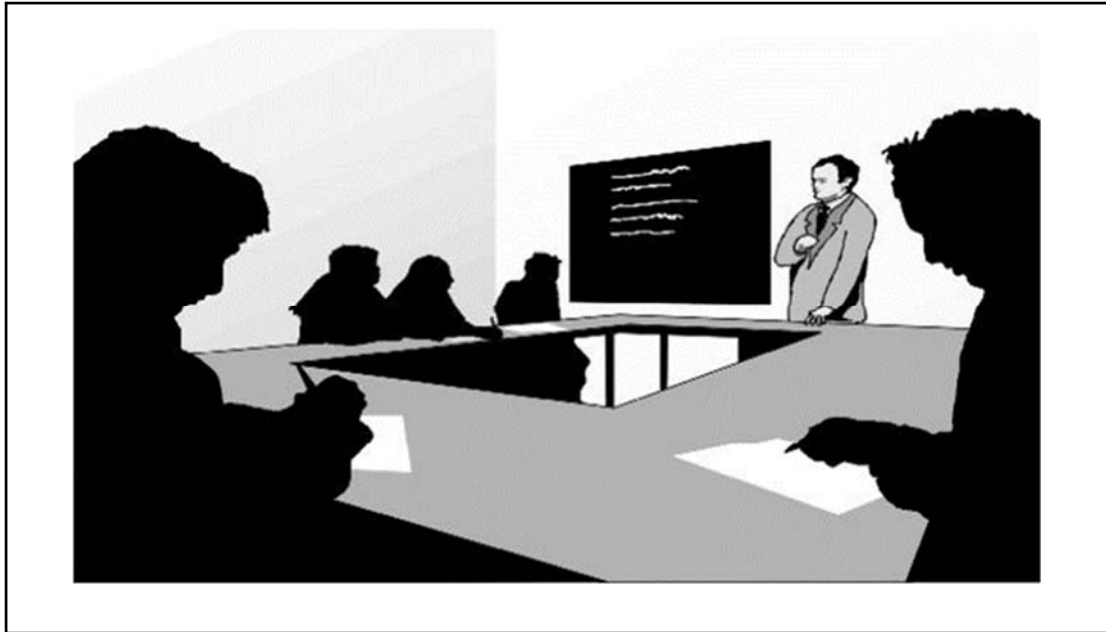
**DESCRIPTION:**

Employee training, like equipment maintenance, is a method by which to implement BMPs. Employee training should be used in conjunction with all other BMPs as part of the facility's SWPPP.

The specific employee training aspects of each of the source controls are highlighted in the individual information sheets. The focus of this information sheet is more general, and includes the overall objectives and approach for assuring employee training in stormwater pollution prevention. Accordingly, the organization of this information sheet differs somewhat from the other information sheets in this chapter.

OBJECTIVES:

Employee training should be based on four objectives:

- ◆ Promote a clear identification and understanding of the problem, including activities with the potential to pollute stormwater;
- ◆ Identify solutions (BMPs);
- ◆ Promote employee ownership of the problems and the solutions; and
- ◆ Integrate employee feedback into training and BMP implementation.

APPROACH:

- ◆ Integrate training regarding stormwater quality management with existing training programs that may be required for your business by other regulations.
- ◆ Businesses that are not regulated in Federal, State, or local regulations, may use the information in this handbook to develop a training program to reduce their potential to pollute stormwater.
- ◆ Employee training is a vital component of many of the individual source control BMPs included in this manual.

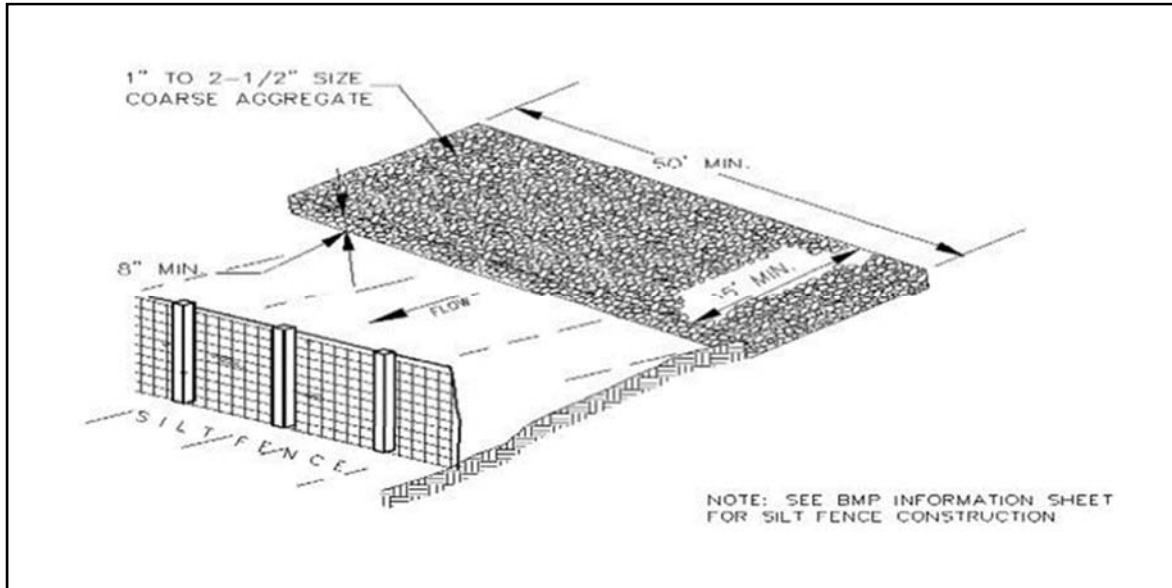
**DESCRIPTION:**

A stabilized pad of crushed stone for general washing of equipment and construction vehicles.

APPLICATION:

- ◆ At any site where regular washing of vehicles and equipment will occur.
- ◆ May also be used as a filling point for water trucks limiting erosion caused by overflow or spillage of water.

INSTALLATION:

- ◆ Clear and grub area and grade to provide maximum slope of 1%.
- ◆ Compact subgrade and place filter fabric if desired (recommended for wash areas to remain in use for more than 3 months).
- ◆ Place coarse aggregate, 1 to 2-1/2 inches in size, to a minimum depth of 8-inches.
- ◆ Install silt fence down gradient (see silt fence BMP information sheet).

LIMITATIONS:

- ◆ Cannot be utilized for washing equipment or vehicles that may cause contamination of runoff such as fertilizer equipment or concrete equipment. Solely used to control sediment in wash water.

MAINTENANCE:

- ◆ Inspect daily for loss of gravel or sediment buildup.
- ◆ Inspect adjacent area for sediment deposit and install additional controls as necessary.
- ◆ Repair area and replace gravel as required to maintain control in good working condition.
- ◆ Expand stabilized area as required to accommodate activities.
- ◆ Maintain silt fence as outlined in specific silt fence BMP information sheet.

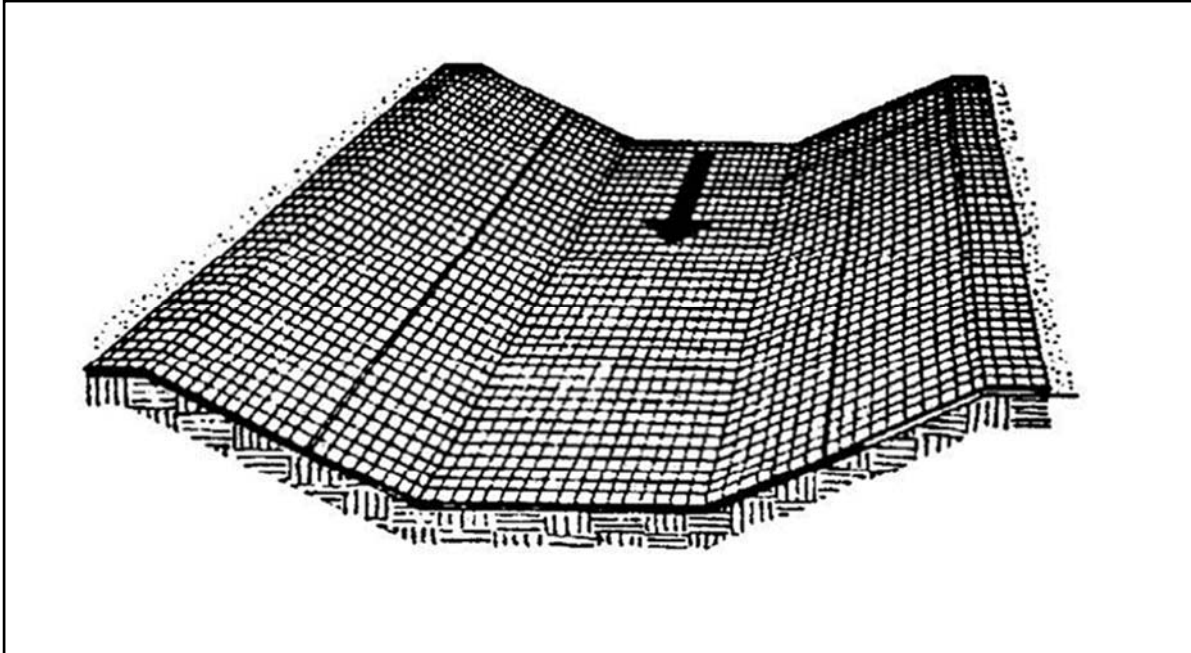
**DESCRIPTION:**

Erosion control blankets are used in place of mulch on areas of high velocity runoff and/or steep grade, to aid in controlling erosion on critical areas by protecting young vegetation.

APPLICATIONS:

- ◆ Where vegetation is likely to grow too slowly to provide adequate cover.
- ◆ In areas subject to high winds where mulch would not be effective.

INSTALLATION/APPLICATION CRITERIA:

- ◆ Install erosion control blankets parallel to the direction of the slope.
- ◆ In ditches, apply in direction of the flow.
- ◆ Place erosion control blankets loosely on soil - do not stretch.
- ◆ Ends of blankets should be buried no less than six inches deep.
- ◆ Staple the edges of the blanket at least every three feet.

LIMITATIONS:

- ◆ Not recommended in areas which are still under construction.

MAINTENANCE:

- ◆ Check for erosion and undermining periodically, particularly after rainstorms.
- ◆ Repair dislocations or failures immediately.
- ◆ If washouts occur, reinstall after repairing slope damage.
- ◆ Monitor until permanently stabilized.

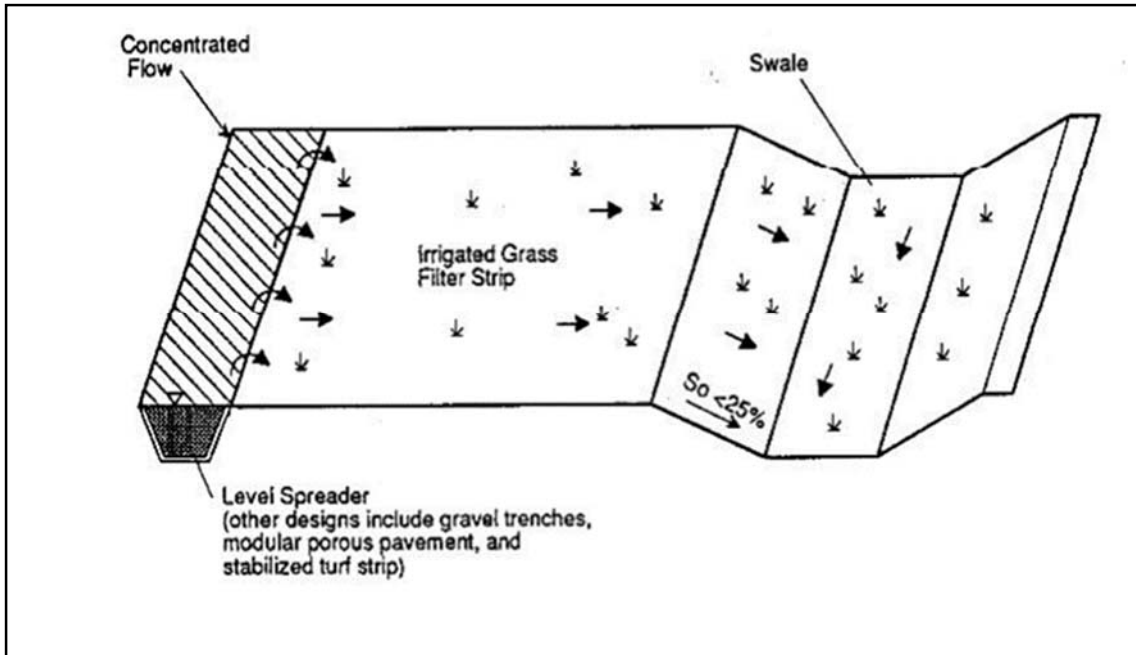

DESCRIPTION:

Filter strips are 20-foot-wide strips of natural or planted vegetation around a construction site. They are designed to cause deposition of sediments within the vegetation layer.

APPLICATIONS:

- ◆ Suited for areas where the soils are well drained or moderately well drained.
- ◆ Areas where the bedrock and the water table are well below the surface.

INSTALLATION/APPLICATION CRITERIA:

- ◆ Make sure the vegetative cover is dense enough to protect underlying soil while causing sediment to settle.
- ◆ Filter strip must be approximately 20 feet wide to function well.
- ◆ The length should be approximately 50 to 75 feet. Where slopes become steeper the length of the strip must be increased.

LIMITATIONS:

- ◆ Only applicable in areas where vegetation is previously established or where sod is added.
- ◆ Vegetated filter strips will not function well on steep slopes, in hilly areas, or in highly paved areas.
- ◆ Sites with slopes of 15 percent or more may not be suitable for filtering storm water flows.

MAINTENANCE:

- ◆ Check for channels and repair.
- ◆ Provide rock aprons to aid in slowing flow if necessary.
- ◆ Maintain vegetation at optimal height and thickness.

APPLICATION:

- Construction projects considered completed that will have bare, unimproved, erodible surfaces
- Projects with temporary exposed surfaces exceeding the CGP cover and time limits.
- A Final Stabilization Plan is necessary for all projects. The final stabilization CGP goal is when the final landscape plan achieves surface stabilization of 70% uniformly distributed cover by either finish grade mulch or established vegetation.

INSTALLATION/USE PROCEDURES:

- Attach a copy of the final landscaping plan, including but not limited to vegetation establishment periods.
- Attach a copy temporary vegetation, including but not limited to temporary seed plan, chemical treatment of erodible surfaces, erosion control blankets, etc,
- Provide a list of all the SWPPP erosion, operation and fugitive dust BMPs that must remain in place through the final stabilization installation and establishment period.
- Ensure the workforce is informed of the final stabilization BMP requirements.

OPERATOR BMP MODIFICATION OR REPLACEMENT:

- Operator is expected to submit a site specific final stabilization plan attached to this BMP. This may include: Proprietary system literature, illustrations, any operation procedures and maintenance required to achieve storm water pollution prevention and final stabilization.

MAINTENANCE/MANAGEMENT:

- Ensure all other SWPPP containment BMPs are installed, maintained and inspected throughout the installation of the final landscaping infrastructure and vegetation establishment period.
- Train workforce when final stabilization plan and site BMP non-containment is recognized.

PERFORMANCE:

A Final Stabilization Plan is not effective when any of the following occurs:

- Erosion occurs beyond the disturbance boundary or sediment is leaving the site.
- A pollutant risk to water quality is present.
- Fugitive dust opacity exceeds DAQ Permit requirements which is usually opacity exceeding 10% at the property boundary.
- Any neighbor complaints warrants an inspection.

REFERENCE:

- UAC section R307-309-5
- CGP 2.2.6, 2.2.14, 2.2.14.a, 7.3.5.b
- CPP 2.2.14, 8.2.1

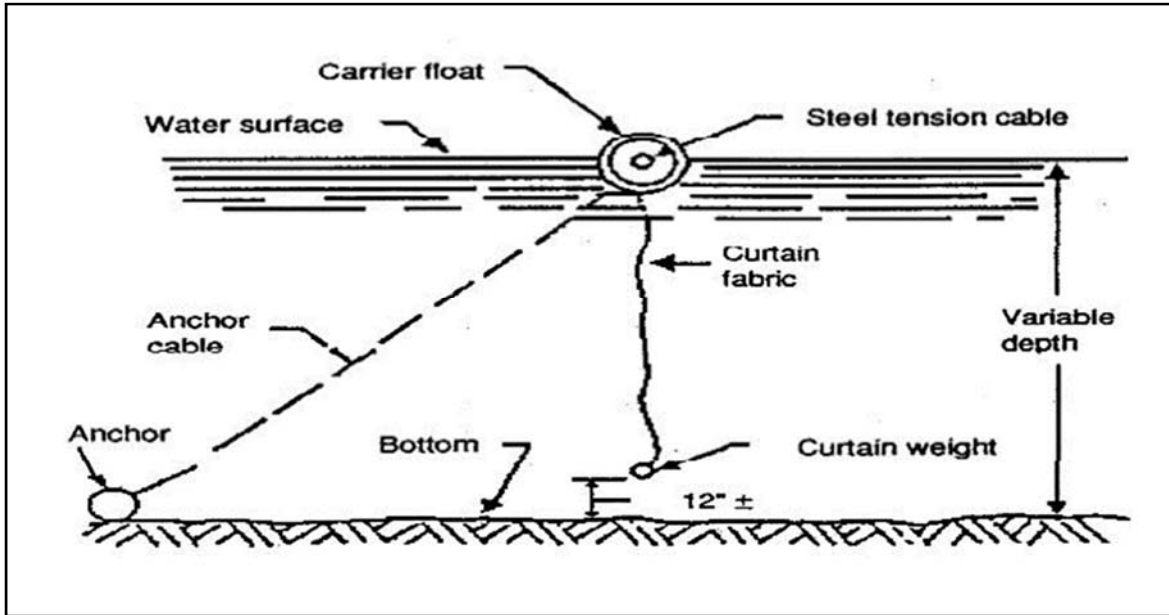

DESCRIPTION:

A flotation silt curtain is a silt barrier for use within a lake or pond. The flotation silt curtain consists of a filter fabric curtain weighted at the bottom and attached to a flotation device at the top. This structure is used to isolate an active construction area within a lake or pond to prevent silt-laden water from migrating out of the construction zone.

APPLICATIONS:

- ◆ Where construction is conducted within a lake or pond area.

INSTALLATION/APPLICATION CRITERIA:

- ◆ The curtain should be constructed of a nylon fabric with a minimum tensile strength of 300 pounds per inch of fabric.
- ◆ The top of the curtain should have a flotation carrier consisting of a floating plastic tube (6 -inch minimum diameter) filled with marine quality polyethylene foam. The flotation carrier should also have a 5/16" diameter coated steel cable in it to carry loads imposed upon the curtain.
- ◆ The bottom edge should be weighted by cable or chain with a minimum weight of 1.1 pounds per foot.
- ◆ One 24-pound anchor should be used per 100 feet of curtain.
- ◆ Where the curtain is made up of sections, the sections should be joined so that silt cannot permeate through the connection.

LIMITATIONS:

- ◆ Not recommended in very shallow water bodies.

MAINTENANCE:

- ◆ The silt curtain should be maintained until the construction area is stabilized and turbidity is reduced to acceptable levels.

APPLICATION:

- ◆ Dust control applies to any bare earth on the project that is at risk of being picked up by wind erosion.
- ◆ Dust suppression is necessary for all areas where vegetation is removed.
- ◆ A good BMP for dust management is to minimize and phase vegetation removal. See Phase Clearing BMP.

INSTALLATION/USE PROCEDURES:

- ◆ Attach a copy of the Fugitive Dust Control Plan and DAQ permit information
- ◆ Attach a copy of the Dust Control Plan Tools and details for suppression, including but not limited to equipment information, methods, and responsible party (inhouse or subcontracted)
- ◆ Attach a list of all dust generating operations, including but not limited to; vehicle traffic, dirt processing, load and haul, brick mason operations, etc.
- ◆ Ensure the workforce is trained regarding track-out BMP requirements.

OPERATOR BMP MODIFICATION OR REPLACEMENT:

- ◆ Operator is invited to propose an alternative BMP or modify this preferred BMP. The proposed BMP must match or exceed performance requirements as this preferred BMP. Any deviations from this preferred BMP must be reviewed and accepted by the oversight authority.
- ◆ Submit BMP modifications or replacements to the oversight authority for review; including but not limited to; Proprietary system literature, modified illustrations, any operation procedures and maintenance adjustments, etc.

MAINTENANCE/MANAGEMENT:

- ◆ Implement Fugitive Dust Control plan per DAQ permit.
- ◆ Train workforce when BMP improper use is recognized.

PERFORMANCE:

- ◆ UAC section R307-309-5. Typically this means no greater than 10% opacity at property boundaries.
- ◆ Any neighbor complaints warrants reevaluation of the effectiveness of the dust control plan and/or an inspection by the oversight authority.

REFERENCE:

- ◆ UAC section R307-309-5
- ◆ CGP 2.2.6
- ◆ CPP 2.2.6

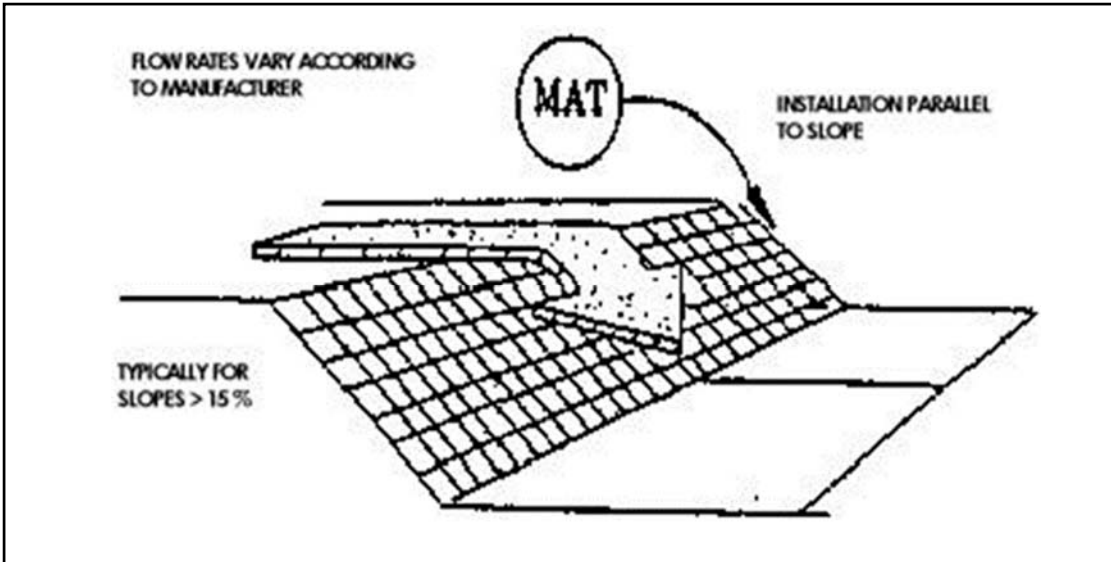

DESCRIPTION:

Mattings made of natural or synthetic material which are used to temporarily or permanently stabilize soil.

APPLICATIONS:

- ◆ Typically suited for post-construction site stabilization, but may be used for temporary stabilization of highly erosive soils.
- ◆ Channels and streams.
- ◆ Steep slopes.

INSTALLATION/APPLICATION CRITERIA:

- ◆ Mattings may be applied to disturbed soils and where existing vegetation has been removed.
- ◆ The following organic matting materials provide temporary protection until permanent vegetation is established, or when seasonal circumstances dictate the need for temporary stabilization until weather or construction delays are resolved: Jute mattings and straw mattings.
- ◆ The following synthetic mattings may be used for either temporary or post-construction stabilization, both with and without vegetation: excelsior matting, glass fiber matting, and mulch matting.
- ◆ Staples are needed to anchor the matting.

LIMITATIONS:

- ◆ Mattings are more costly than other BMP practices, limiting their use to areas where other BMPs are ineffective (e.g., channels, steep slopes).
- ◆ May delay seed germination, due to reduction in soil temperature.
- ◆ Installation requires experienced contractor to ensure soil stabilization and erosion protection.

MAINTENANCE:

- ◆ The silt curtain should be maintained until the construction area is stabilized and turbidity is reduced to acceptable levels.

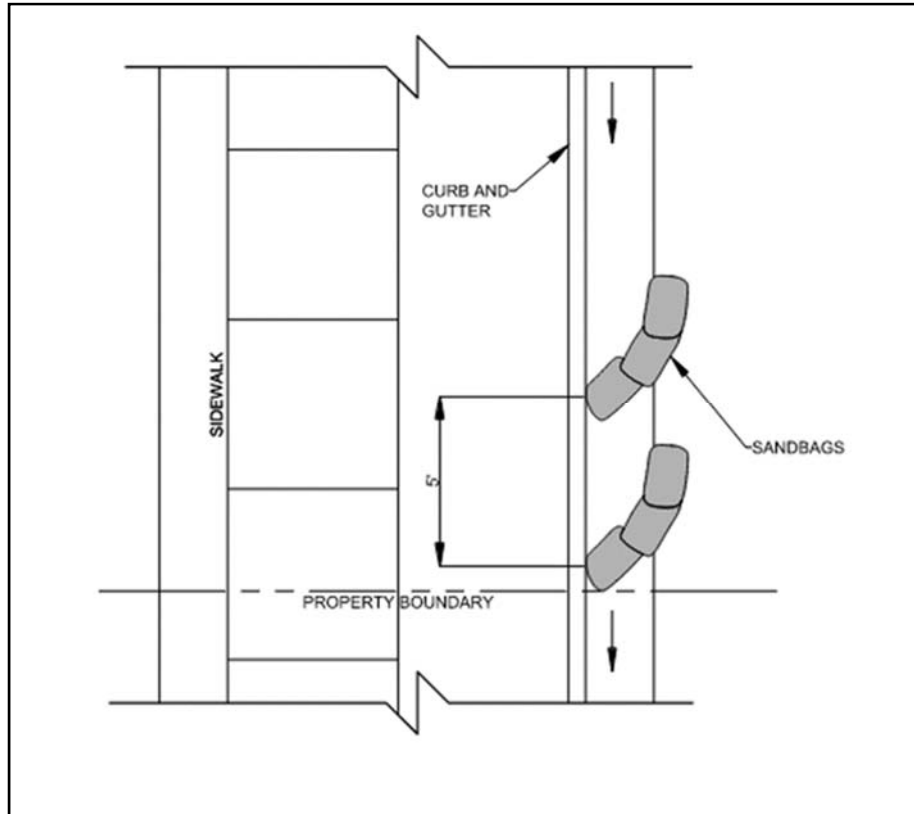

APPLICATION:

- ◆ This BMP allows sediment laden storm water to be filtered by the gutter dam minimizing sediment from reaching downstream inlets.
- ◆ This BMP allows for runoff by-pass during intense storm events but when adequately maintained can minimize sediment by-pass common with many inlet cover only BMPs. Inlet cover only BMPs should have secondary containment built in or coupled with downstream BMPs to contain sediment and debris by-pass.
- ◆ Use Gutter Dam BMP when the project is expected to contain its impact from other operators downstream BMPs. This is a common concern between operators when multiple independent builders are building homes in the same subdivision.
- ◆ **Warning:** This BMP is easily damaged by vehicles that park along the curb and gutter, and by snow removal operations.

INSTALLATION/USE PROCEDURES:

- ◆ Install 6" min diameter sand or gravel bags. Double up bags as necessary.
- ◆ Install upstream of inlets.
- ◆ This gutter dam system is working when the first dam is holding more sediment than the downstream dams. When the sediment collection is about the same then something is wrong.
- ◆ This system can scour out easily and needs regular maintenance to be effective.
- ◆ Inform subcontractors and suppliers of the gutter dams placement to roadside parking from damaging the sand or gravel bags.
- ◆ Train SWPPP inspection and maintenance team
- ◆ This BMP is designed for 1/4" (~2yr 10min intensity) rain storm events.

OPERATOR BMP MODIFICATION OR REPLACEMENT:

- ◆ Operator is invited to propose an alternative BMP or modify this preferred BMP. The proposed BMP must match or exceed performance requirements as this preferred BMP. Any deviations from this preferred BMP must be reviewed and accepted by the oversight authority.
- ◆ Submit BMP modifications or replacements to the oversight authority for review; including but not limited to; Proprietary system literature, modified illustrations, any operating procedures and maintenance adjustments, etc.

MAINTENANCE/MANAGEMENT:

- ◆ Anticipate significant storm events, repair damage and remove sediment deposits prior to storm events that could scour sediment deposits from the gutter dam.
- ◆ Inspect, remove sediment and repair gutter dam regularly during the report period and following each storm event.
- ◆ Following storm events the first dam should have more sediment than the downstream dams.
- ◆ When inspection shows failure persists, even with regular maintenance, a third dam should be installed. If the gutter dam system does not perform as intended, a different or additional BMP is warranted.
- ◆ Bring awareness to workforce and suppliers parking near the gutter dam.
- ◆ Check during storm events and prevent driving hazardous resulting from surface water conditions.

PERFORMANCE:

- ◆ A gutter dam system is expected to slow the flow of runoff in the gutter to allow for sediment deposition. Erosion control of non-stabilized sediment should be used in conjunction with a gutter dam system. This BMP should be utilized as a secondary control to erosion control BMPs.

It is considered a BMP failure when any of the following occur:

- ◆ When storm events less than 1/4" of rain results in significant scour an alternative BMP is warranted.
- ◆ When regular damage occurs to the gutter dam system due to traffic or snow operations an alternative BMP is warranted.
- ◆ When sediment deposits are equal to or greater in the downstream dam following storm events of 1/4" or less, the BMP is not adequate and warrants a different BMP.

REFERENCE:

- ◆ CGP 2.2.10
- ◆ CPP 2.1



DESCRIPTION:

Prevent or reduce the discharge of pollutants to stormwater from hazardous waste through proper material use, waste disposal, and training of employees and subcontractors.

APPLICATIONS:

Many of the chemicals used on-site can be hazardous materials which become hazardous waste upon disposal. These wastes may include:

- ◆ Paints and solvents;
- ◆ Petroleum products such as oils, fuels, and grease;
- ◆ Herbicides and pesticides;
- ◆ Acids for cleaning masonry; and
- ◆ Concrete curing compounds

In addition, sites with existing structures may contain wastes which must be disposed of in accordance with Federal, State, and local regulations, including:

- ◆ Sandblasting grit mixed with lead, cadmium, or chromium-based paints;
- ◆ Asbestos; and
- ◆ PCBs.

INSTALLATION/APPLICATION CRITERIA:

The following steps will help reduce storm water pollution from hazardous wastes:

- ◆ Use all of the product before disposing of the container.
- ◆ Do not remove the original product label, it contains important safety and disposal information.
- ◆ Do not over-apply herbicides and pesticides. Prepare only the amount needed. Follow the recommended usage instructions. Over-application is expensive and environmentally harmful. Apply surface dressings in several smaller applications, as opposed to one large application, to allow time for infiltration and to avoid excess material being carried off-site by runoff. Do not apply these chemicals just before it rains. People applying pesticides must be certified in accordance with Federal and State regulations.

LIMITATIONS:

- ◆ Hazardous waste that cannot be reused or recycled must be disposed of by a licensed hazardous waste hauler.

MAINTENANCE:

- ◆ Inspect hazardous waste receptacles and area regularly.
- ◆ Arrange for regular hazardous waste collection.

**DESCRIPTION:**

A combination of wood fiber mulch, processed grass, or hay or straw mulch and a tacking agent. It is made into a slurry, then applied to bare slopes or other bare areas to provide temporary stabilization.

APPLICATIONS:

- ◆ Small roadside slopes.
- ◆ Large, relatively flat areas.

INSTALLATION/APPLICATION CRITERIA:

- ◆ Legume seeds should be pellet inoculated with the appropriate bacteria.
- ◆ The seed should not remain in the hydromulcher tank for more than 30 minutes.
- ◆ Wood fiber may be dyed to aid in uniform application.
- ◆ Slurry should be uniformly applied until an adequate coverage is achieved.
- ◆ The applicator should not be directed at one location for a long period of time; erosion will occur.

LIMITATIONS:

- ◆ Will lose effectiveness after 1 year.
- ◆ Can use only on physically stable slopes (at natural angle of repose, or less).

MAINTENANCE:

- ◆ Periodically inspect for damage caused by wind, water, or human disturbance.
- ◆ Promptly repair damaged areas.

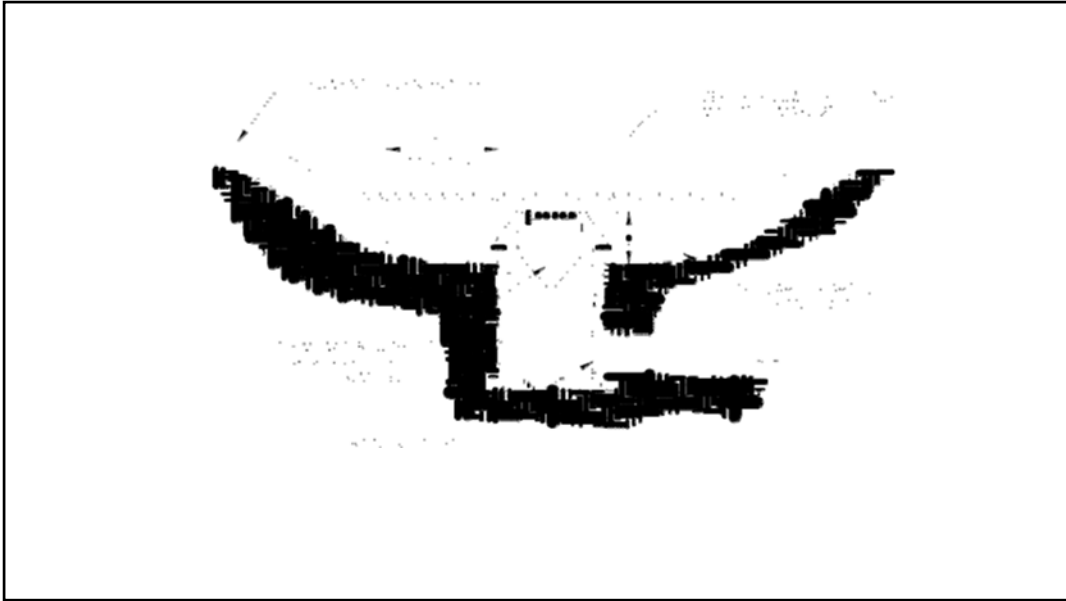
**DESCRIPTION:**

An area excavated around a storm drain inlet to impound water below the inlet.

APPLICATION:

- ◆ Construct at storm drainage inlets located down gradient of areas to be disturbed by construction (for inlets in paved areas see other information sheets for inlet protection).

INSTALLATION/APPLICATION CRITERIA:

- ◆ Provide up gradient sediment controls, such as silt fence during construction of inlet.
- ◆ When construction of inlet is complete, excavate adjacent area 1 to 2 feet lower than the grate elevation. Size of excavated area should be based on soil type and contributing acreage.

LIMITATIONS:

- ◆ Recommended maximum contributing drainage area of one acre.
- ◆ Limited to inlets located in open unpaved areas.
- ◆ Requires flat area adjacent to inlet.

MAINTENANCE:

- ◆ Inspect inlet protection following storm event and at a minimum of once monthly.
- ◆ Remove accumulated sediment when it reaches one half of the excavated sump below the grate.
- ◆ Repair side slopes as required.

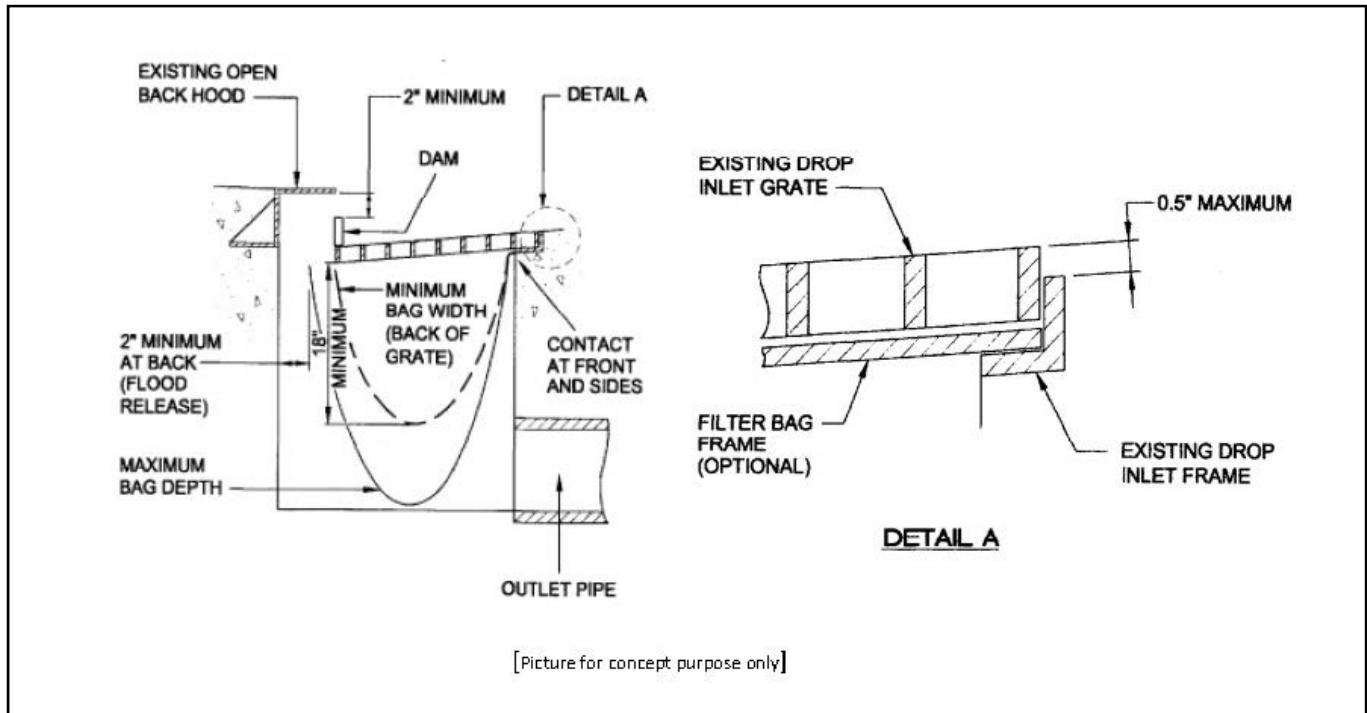

APPLICATION:

- ◆ Use drop inlet bag BMPs with overflow systems at roadway sag locations. Note, these BMP can be appropriate on collector roadways when inspections show success at preventing surface ponding. Note, the local municipality will need to evaluate the traffic risk on a case by case basis.
- ◆ Use drop inlet bag BMPs when other surface inlet BMPs like sand bags are less feasible due to high traffic in the area.

INSTALLATION/USE PROCEDURES:

- ◆ Attach drop inlet bag proprietary manufacturer installation and maintenance detail literature to this BMP. Provide drop inlet bag system designed for inlet type needed, e.g. open face, not open face gutter, etc.
- ◆ Install the drop inlet bag system in accordance with the manufacturer literature.

OPERATOR BMP MODIFICATION OR REPLACEMENT:

- ◆ Operator is invited to propose an alternative BMP or modify this preferred BMP. The proposed BMP must match or exceed performance requirements as this preferred BMP. Any deviations from this preferred BMP must be reviewed and accepted by the oversight authority.
- ◆ Submit BMP modifications or replacements to the oversight authority for review; including but not limited to; Proprietary system literature, modified illustrations, any operation procedures and maintenance adjustments, etc.

MAINTENANCE/MANAGEMENT:

- ◆ Inspect and maintain if necessary every report period. **Empty and dispose of debris accumulations when the bag capacity has reached 50% full or before the bag becomes unmanageable or ineffective.**
- ◆ Inspect the unit prior to and after storm events. Large storm events will scour sediment from almost all roadway inlet BMPs, therefore regular maintenance is the best management practice.
- ◆ Remove and dispose of any sediment found inside the inlet box resulting from BMP failure or resulting during maintenance operations.
- ◆ Conduct any maintenance required by the drop inlet bag manufacturer.
- ◆ In collector roadways or other locations oversight authority requires, check during storm events and prevent hazardous driving conditions.

PERFORMANCE:

- ◆ A drop inlet bag is expected to prevent debris and large sediment particles from entering a storm drain.
- ◆ Minor ponding should be expected, but the overflow would prevent excessive ponding
- ◆ A drop inlet bag should not allow the accumulated debris to fall into the structure it is protecting at anytime both during maintenance and removal. The design and installation specifications should support this ideal.

It is considered a BMP failure when any of the following occur:

- ◆ System not installed or maintained to installation and operation requirements.
- ◆ System not installed and maintained to manufacturer requirements.
- ◆ Sediment scour resulting from irregular maintenance.
- ◆ Sediment left in inlet following maintenance.
- ◆ Excessive ponding resulting from irregular maintenance or blocked overflow.

REFERENCE:

- ◆ CGP 2.2.10
- ◆ CPP 2.1.3

FG-TB-0001

| SPECIFIER CHART | | |
|-----------------|-----------------------------------------------------|--------------------------------|
| MODEL NO. | CATCH BASIN ID Inside Dimension (inch x inch) | CURB DAM OPTION (YES/NO) |
| FG-TB24 | 24X24 | NO |
| FG-TB24D | 24X24 | YES |
| FG-TB2436 | 24X36 | NO |
| FG-TB2436D | 24X36 | YES |
| FG-TB36 | 36X36 | NO |
| FG-TB36D | 36X36 | YES |

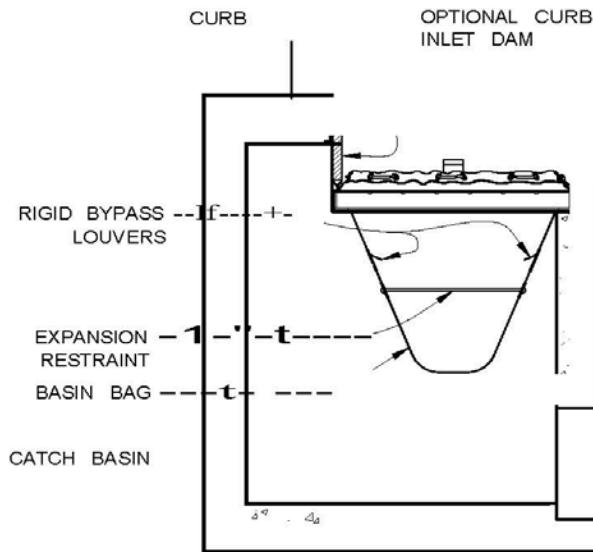
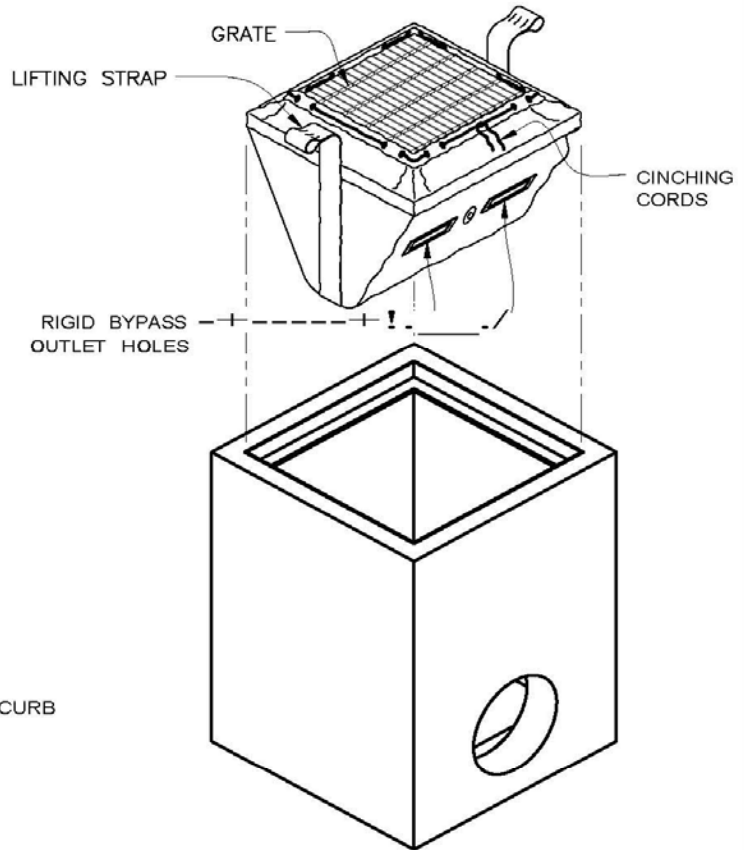

**SECTION VIEW
-INSTALLED-
WITH OPTIONAL CURB INLET DAM**

NOTES:

1. FloGard® T-Bag™ is manufactured from woven monofilament polypropylene fabric. Other materials available upon request.
2. May be ordered with *Fossil Rock™* oil absorbent pouches installed.
3. Optional curb inlet dam available upon request.
4. Periodic maintenance is required. FloGard® T-Bag™ should never be allowed to fill beyond the top of the bypass outlet louvers.
5. Appropriate lifting equipment should be used when performing periodic maintenance.

TITLE

®T-BAG™

TEMPORARY INLET PROTECTION DEVICE



KriStar Enterprises, Inc.

360 Sutton Place, Santa Rosa, CA 95407
Ph: 800.579.8819, Fax: 707.524.8186, www.kristar.com

DRAWING NO. REV. ECD DATE
FG-TB-0001 A 0059 JPR 12/30/03 JPR 09/01/06 SHEET 1 OF 1

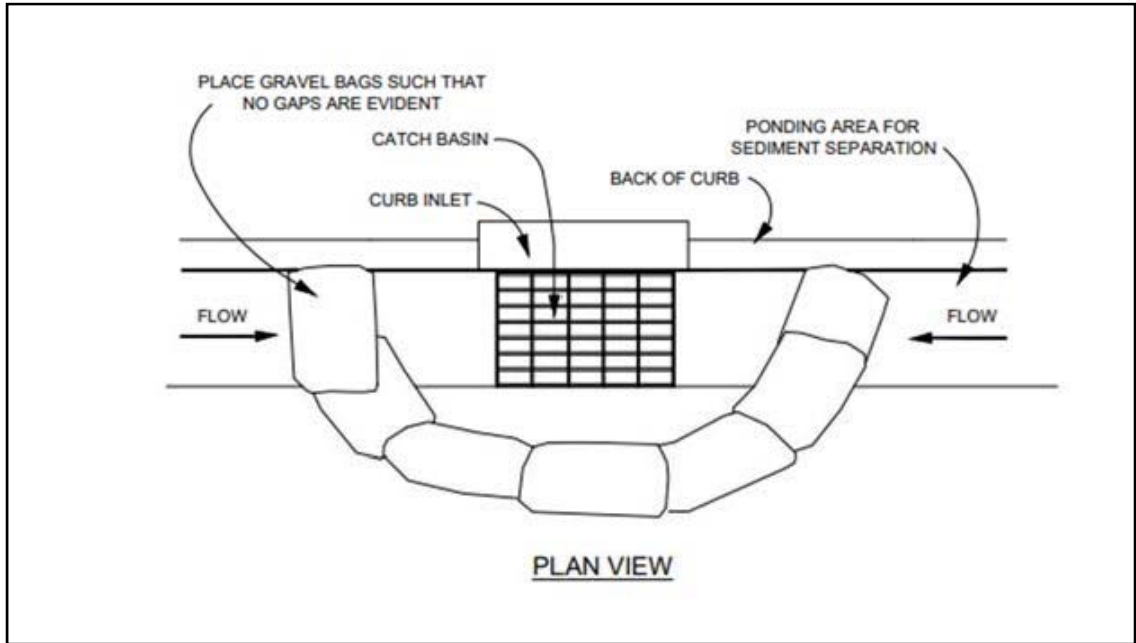

APPLICATION:

- ◆ The purpose of placing gravel bags around an inlet or other runoff receiving area is to slow the flow of water to allow sediment deposition to be maximized before runoff enters the inlet or other receiving area.
- ◆ Ideal for areas near storm drains, curb inlets, and other drainage structures.
- ◆ Not intended for high-flow areas without additional support measures.
- ◆ Do not use on collector roadways and where the control could create safety concerns such as hydroplaning.

INSTALLATION/USE PROCEDURES:

- ◆ Ensure the bags are properly positioned to maximize the area available for ponding.
- ◆ Use appropriate types of inlet protection based on site-specific conditions.
- ◆ Install inlet protection measures that remove sediment from discharges prior to entry into any storm drain inlet that carries storm water flow from your site to surface water of the state, provided you have authority to access the storm drain inlet.
- ◆ This BMP is designed for 1/4" (~2yr 10min intensity) rain storm events.
- ◆ Train SWPPP inspection and maintenance team

OPERATOR BMP MODIFICATION OR REPLACEMENT:

- ◆ Operator is invited to propose an alternative BMP or modify this preferred BMP. The proposed BMP must match or exceed performance requirements as this preferred BMP. Any deviations from this preferred BMP must be reviewed and accepted by the oversight authority.
- ◆ Submit BMP modifications or replacements to the oversight authority for review; including but not limited to; Proprietary system literature, modified illustrations, any operation procedures and maintenance adjustments, etc.

MAINTENANCE/MANAGEMENT:

- ◆ Regularly inspect and maintain the system to ensure proper function.
- ◆ If repairs are needed, repair the system as soon as practicable.

- ◆ Inspect inlet protection before and after storm events or other large volume runoff events.
- ◆ Remove accumulated sediment and debris when deposits are $\frac{1}{3}$ the height of the gravel bag barrier.
- ◆ Ensure a clear area around inlet protection devices to facilitate inspections and maintenance.
- ◆ Check during storm events and prevent hazardous surface water driving conditions.

PERFORMANCE:

- ◆ Inlet protection is considered effective if it mitigates target pollutants from entering the stormwater system.
- ◆ Inlet protection system resulting in spill over during an event less than 1/4" (~2yr 10min intensity) of rain is considered a failure.

REFERENCE:

- ◆ CGP- 2.2.10
- ◆ CPP- 2.1.3

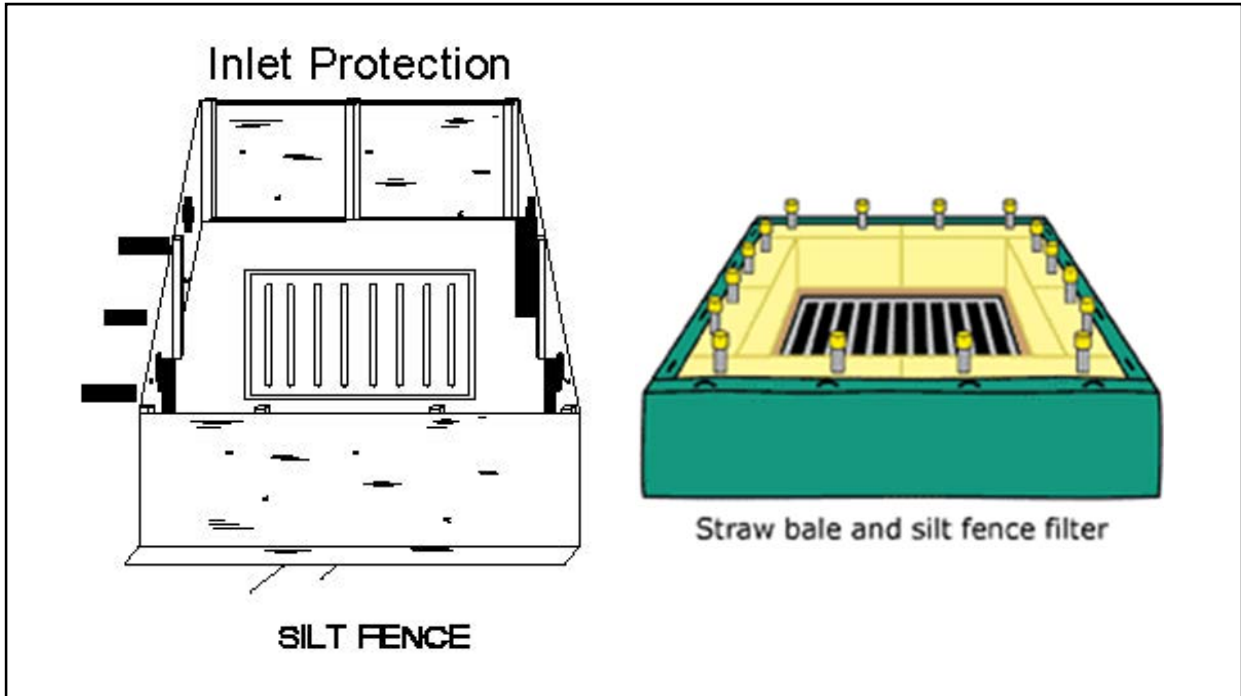

DESCRIPTION:

Sediment barrier erected around storm drain inlet.

APPLICATION:

- ◆ Construct at storm drainage inlets located down gradient of areas to be disturbed by construction (for inlets in paved areas see other information sheets for inlet protection).

INSTALLATION/APPLICATION CRITERIA:

- ◆ Provide up gradient sediment controls, such as silt fence during construction of inlet.
- ◆ When construction of inlet is complete, erect straw bale barrier or silt fence surrounding perimeter of inlet. Follow instructions and guidelines on individual BMP information sheets for straw bale barrier and silt fence construction.

LIMITATIONS:

- ◆ Recommended maximum contributing drainage area of one acre.
- ◆ Limited to inlets located in open unpaved areas.
- ◆ Requires shallow slopes adjacent to inlet.

MAINTENANCE:

- ◆ Inspect inlet protection following storm event and at a minimum of once monthly.
- ◆ Remove accumulated sediment when it reaches 4-inches in depth.
- ◆ Repair or realign barrier/fence as needed.
- ◆ Look for bypassing or undercutting and recompact soil around barrier/fence as required.

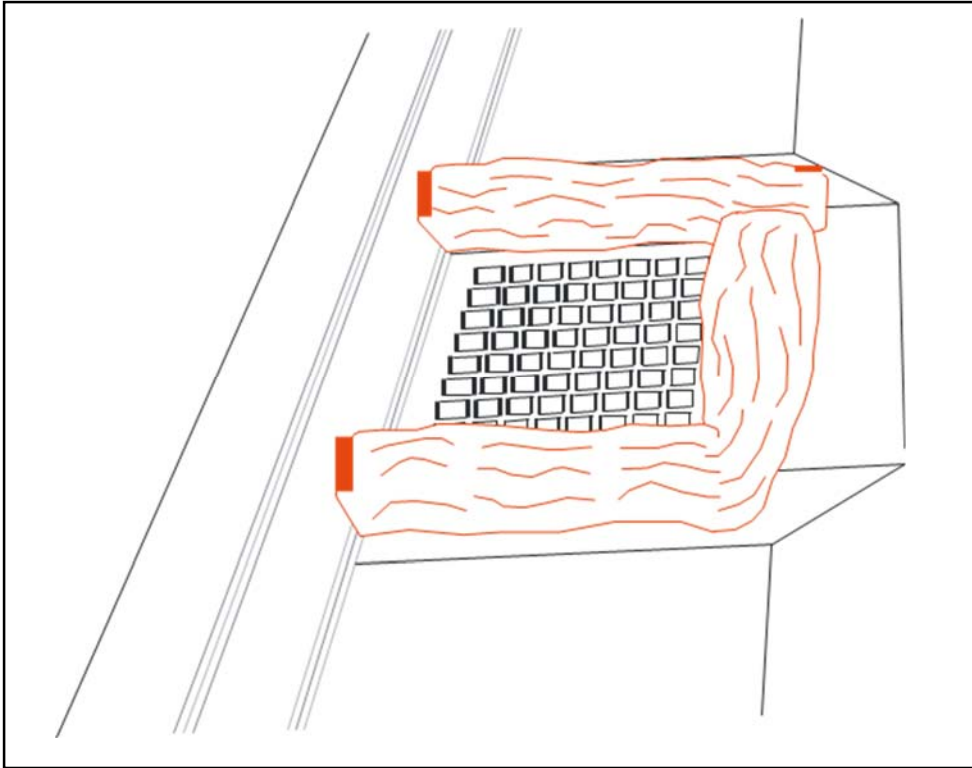
**DESCRIPTION:**

Sediment barrier erected around storm drain inlet.

APPLICATION:

- ◆ Construct at storm drainage inlets located down-gradient of areas to be disturbed by construction.

INSTALLATION/APPLICATION CRITERIA:

- ◆ Provide up-gradient sediment controls, such as silt fence during construction of inlet
- ◆ When construction of curb and gutter and roadways is complete, install gravel filled wattles around perimeter of inlet

LIMITATIONS:

- ◆ Recommended maximum contributing drainage area of one acre
- ◆ Requires shallow slopes adjacent to inlet

MAINTENANCE:

- ◆ Inspect inlet protection following storm event and at a minimum of once every 14 days.
- ◆ Remove accumulated sediment when it reaches 4 inches in depth.
- ◆ Look for bypassing or undercutting and repair or realign as needed.

**DESCRIPTION:**

Stormwater control BMPs need regular inspections to ensure their effectiveness, and is required by the DWQ construction permit. Routine inspections are required on a bi-weekly basis; before and after anticipated storm events. Proper maintenance is crucial to compliance with the permit and to minimize erosion.

Routine inspections help to ensure the integrity and effectiveness of BMPs; inspections prior to a rain event ensure that BMPs are cleaned out and operating properly; inspections following a rain event serve to prepare the site for the next event. Maintenance should be conducted when problems are identified.

APPLICATION:

- ◆ Inspections and maintenance is required by the DWQ permit at all sites.
- ◆ Maintenance needs are best determined by a self-inspection program.

INSTALLATION/APPLICATION CRITERIA:

- ◆ The person responsible for the inspections should be trained in the design and operation of the BMPS.

LIMITATIONS:

- ◆ Construction site operators should allocate adequate time and resources for BMP maintenance and repair.

**DESCRIPTION:**

Land grading involves reshaping the ground surface to planned grades as determined by an engineering survey, evaluation, and layout. Land grading provides more suitable topography for buildings, facilities, and other land uses and helps to control surface runoff, soil erosion, and sedimentation during and after construction.

APPLICATION:

- ◆ Land grading is applicable to sites with uneven or steep topography or easily erodible soils, because it stabilizes slopes and decreases runoff velocity.
- ◆ Grading activities should maintain existing drainage patterns as much as possible.

INSTALLATION/APPLICATION CRITERIA:

- ◆ Before grading activities begin, a construction site operator must make decisions regarding the steepness of cut-and-fill slopes and how the slopes will be: Protected from runoff, stabilized and maintained.

LIMITATIONS:

- ◆ Improper grading practices that disrupt natural stormwater patterns might lead to poor drainage, high-runoff velocities, and increased peak flows during storm events.
- ◆ Clearing and grading the entire site without vegetated buffers promotes offsite transport of sediments and other pollutants.
- ◆ Design the grading plan with erosion and sediment control and stormwater management goals in mind; to ensure that the plan is implemented as intended, carefully supervise grading crews.

MAINTENANCE:

- ◆ Check all graded areas and supporting erosion and sediment control practices periodically, especially after heavy rainfalls.
- ◆ Promptly remove all sediment from diversions or other stormwater conveyances, and if washouts or breaks occur, repair them immediately.
- ◆ To prevent small-scale eroded areas from becoming significant gullies, maintain them promptly.

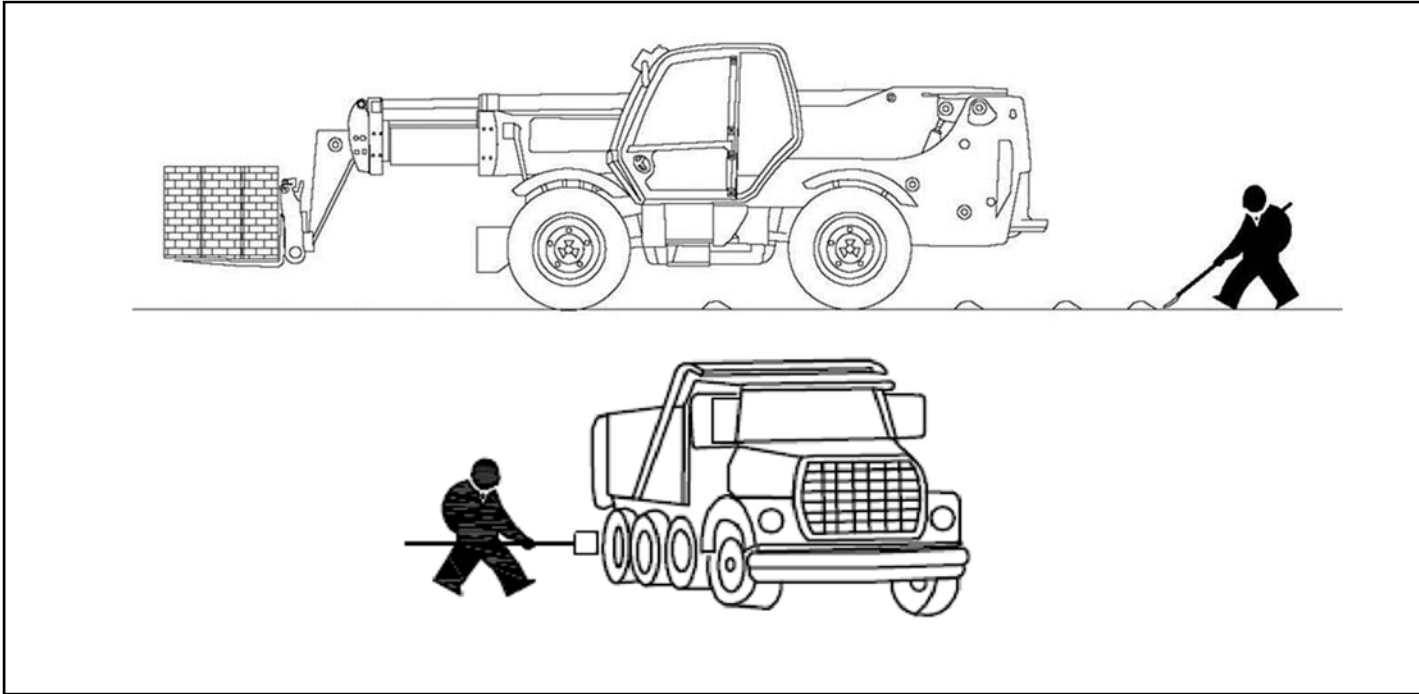

APPLICATION:

- ◆ Use this BMP when vehicles and equipment operations require egress from the project property during wet conditions resulting in mud sticking to vehicle tires and tracks.
- ◆ Use this BMP when non-regular egress is necessary or using the primary track out BMP is not practical for an unusual situation.
- ◆ Use this BMP as a redundant BMP when the primary track out BMP(s) is not working.
- ◆ Use this BMP for short transfer of vehicles for short distances, e.g. across the street.

INSTALLATION/USE PROCEDURES:

- ◆ Stop before exiting the site and use a square nose shovel or stiff broom to remove mud from tires and remove mud tracks when applicable.
 - When manually removing mud on pavement, shovel and sweep with each track out occurrence and always perform this BMP when incidents are upstream of inlets.
- ◆ Check for and remove rocks wedged in dual tires.
- ◆ Ensure the workforce is trained regarding mud removal and cleanup of track out BMP requirements.
- ◆ Use of Sweeping BMP is still usually necessary at the end of day minimum.

OPERATOR BMP MODIFICATION OR REPLACEMENT:

- ◆ Operator is invited to propose an alternative BMP or modify this preferred BMP. The proposed BMP must match or exceed performance requirements as this preferred BMP. Any deviations from this preferred BMP must be reviewed and accepted by the oversight authority.
- ◆ Submit BMP modifications or replacements to the oversight authority for review; including but not limited to; Proprietary system literature, modified illustrations, any operation procedures and maintenance adjustments, etc.

MAINTENANCE/MANAGEMENT:

- ◆ When removing mud from tires or tracks on pavement sweep prior to wet conditions or end of day, whichever comes first.
- ◆ Train workforce when BMP improper use is recognized.
- ◆ When sediment, rock, or gravel track out occurs due to BMP failure or misuse, debris must be removed from roadways according to the CGP criteria.
 - Street clean-up operations are separate from this Manual Mud Removal BMP, but necessary to address unacceptable track out that may occur.

PERFORMANCE:

- ◆ Slick conditions, slurry, mud chunks, rocks, gravel, water quality risk and driver hazards constitute BMP failure and require immediate sufficient action.
- ◆ Light tracking is expected and requires regular maintenance but not usually immediate action. Light tracking is defined as minor residual dirt that can't be picked up by a square nose shovel.
 - Remove/sweep prior to unsafe and wet conditions or end of workday, whichever is first.

REFERENCE:

- ◆ CGP- 2.2.4, 5.1, 5.2.1
- ◆ CPP- 2.4.1

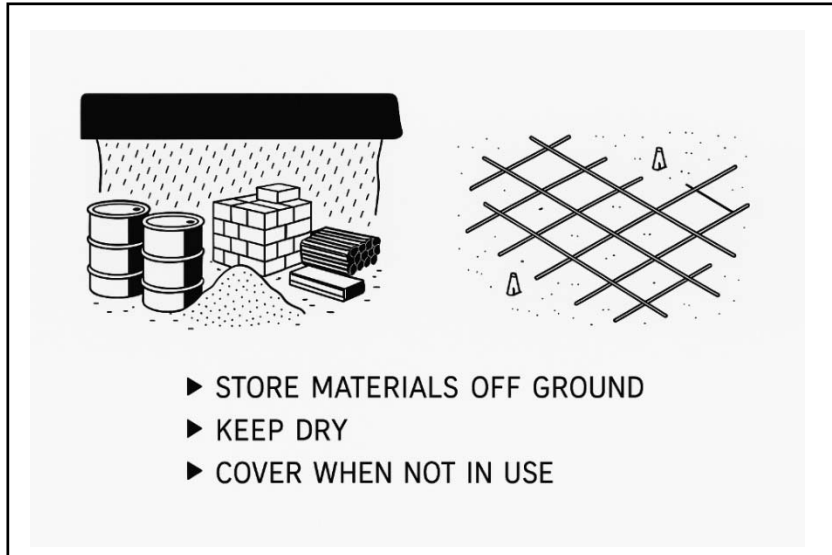
**DESCRIPTION:**

Controlled storage of on-site materials.

APPLICATION:

- ◆ Storage of hazardous, toxic, and all chemical substances.
- ◆ Any construction site with outside storage of materials.

INSTALLATION/APPLICATION CRITERIA:

- ◆ Designate a secured area with limited access as the storage location. Ensure no waterways or drainage paths are nearby.
- ◆ Construct compacted earthen berm (See Earth Berm Barrier Information Sheet), or similar perimeter containment around storage location for impoundment in the case of spills.
- ◆ Ensure all on-site personnel utilize designated storage area. Do not store excessive amounts of material that will not be utilized on site.
- ◆ For active use of materials away from the storage area ensure materials are not set directly on the ground and are covered when not in use. Protect storm drainage during use.

LIMITATIONS:

- ◆ Does not prevent contamination due to mishandling of products.
- ◆ Spill Prevention and Response Plan still required.
- ◆ Only effective if materials are actively stored in controlled location.

MAINTENANCE:

- ◆ Inspect daily and repair any damage to perimeter impoundment or security fencing.
- ◆ Check materials are being correctly stored (i.e. standing upright, in labeled containers, tightly capped) and that no materials are being stored away from the designated location.

**DESCRIPTION:**

Prevent or reduce the discharge of pollutants to storm water from material use by using alternative products, minimizing hazardous material use on-site, and training employees and subcontractors.

APPLICATION:

- ◆ The following materials are commonly used on construction sites:
- ◆ Pesticides and herbicides, fertilizers, detergents, plaster and other products, petroleum products such as fuel, oil, and grease.
- ◆ Other hazardous chemicals such as acids, lime, glues, paints, solvents, and curing compounds.

INSTALLATION/APPLICATION CRITERIA:

- ◆ Use less hazardous, alternative materials as much as possible.
- ◆ Minimize use of hazardous materials on-site.
- ◆ Use only materials where and when needed to complete the construction activity.
- ◆ Follow manufacturer's instructions regarding uses, protective equipment, ventilation, flammability, and mixing of chemicals.
- ◆ Personnel who use pesticides should be trained in their use.
- ◆ Do not over apply fertilizers, herbicides, and pesticides. Prepare only the amount needed.
- ◆ Unless on steep slopes, till fertilizers in to the soil rather than hydroseeding.
- ◆ Do not apply these chemicals just before it rains.

LIMITATIONS:

- ◆ Alternative materials may not be available, suitable, or effective in every case.

MAINTENANCE:

- ◆ Maintenance of this best management practice is minimal.

DESCRIPTION:

Placement of material such as straw, grass, woodchips, wood fibers or fabricated matting over open area.

APPLICATION:

- ◆ Any exposed area to remain untouched longer than 14 days and that will be exposed less than.
- ◆ 60 days (seed areas to be exposed in excess of 60 days).
- ◆ Areas that have been seeded.
- ◆ Stockpiled soil material.

| Material | Application | Depth | Comments |
|-------------------------------------------------------------------------|-------------------|---------------|------------------------------------------------------------------------------------|
| <u>Gravel:</u> Washed 1/4" to 1-1/2" | 9 cy/1000sf | 3 inches | Good for traffic areas Good for short slopes |
| <u>Straw:</u> Air-dried, free of seeds and coarse material | 2-3 bales /1000sf | 2 inches min. | Subjet to wind blowing Tack down or keep moist |
| <u>Wood Fiber Cellulose:</u> Free from growth inhibitors; dyed green | 35 lb/1000 sf | 1 inch | for critical area, double applications rate; Limit to slopes < 3% and <150 feet |

INSTALLATION/APPLICATION CRITERIA:

- ◆ Roughen area to receive mulch to create depressions that mulch material can settle into.
- ◆ Apply mulch to required thickness and anchor as necessary.
- ◆ Ensure material used is weed free and does not contain any constituents that will inhibit plant growth.

LIMITATIONS:

- ◆ Anchoring may be required to prevent migration of mulch material.
- ◆ Down gradient control may be required to prevent mulch material being transported to storm water system.

MAINTENANCE:

- ◆ Inspect mulched areas after every rainfall event and at a minimum of monthly.
- ◆ Replace mulch on any bare areas and re-anchor as necessary.
- ◆ Clean and replace down gradient controls as necessary.

**DESCRIPTION:**

Prevent fuel spills and leaks, and reduce their impacts to storm water by using off-site facilities, fueling in designated areas only, enclosing or covering stored fuel, implementing spill controls, and training employees and subcontractors.

APPLICATION:

Use when fixed onsite fueling tanks are planned.

INSTALLATION/USE PROCEDURES:

- ◆ Locate fueling operations a minimum of 50 feet from receiving waters, constructed or natural site drainage features, and storm drain inlets. If infeasible due to site constraints, store containers as far away from these features as the site permits. If site constraints prevent you from storing containers 50 feet away from the features identified, you must document in your SWPPP the specific reasons why the 50-foot setback is infeasible.
- ◆ Store fuels in sealed, clearly labeled containers.
- ◆ Containers must be covered and/or have secondary containment (curbing, spill berms, dikes, spill containment pallets, double-walled storage tank)
- ◆ Submit illustration or detail for secondary containment of fuel containers and secondary containment used during active fueling (drip pan, drop cloth, etc.)
- ◆ Discourage topping-off of fuel tanks.
- ◆ Carry out all Federal and State requirements regarding stationary above ground storage tanks. (40 CF Sub. J) Avoid mobile fueling of mobile

construction equipment around the site; rather, transport the equipment to designated fueling areas.

- ◆ Create and attach a Spill Plan specific to the project.

- ◆ If you fuel many vehicles or pieces of equipment, consider using an off-site fueling station. These areas are better equipped to handle fuel and spills properly.
- ◆ Provide a copy of your off site written policy to the oversight authority for review

OPERATOR BMP MODIFICATION OR REPLACEMENT:

- ◆ Operator is invited to propose an alternative BMP or modify this preferred BMP. The proposed BMP must match or exceed performance requirements as this preferred BMP. Any deviations from this preferred BMP must be reviewed and accepted by the oversight authority.
- ◆ Submit BMP modifications or replacements to the oversight authority for review; including but not limited to; Proprietary system literature, modified illustrations, any operation procedures and maintenance adjustments, etc.

MAINTENANCE/MANAGEMENT:

- ◆ Fuel equipment in designated areas only
- ◆ Train employees and subcontractors in proper fueling and cleanup procedures.
- ◆ Regularly check for leaks and damage including but not limited to: tanks, hoses, and secondary containment.
- ◆ Keep ample supplies of spill cleanup materials on-site and perform any repairs necessary to contain fuel appropriately immediately.
- ◆ If spill occurs, use dry clean-up methods and dispose of spill clean-up materials to a proper licensed facility.
- ◆ Large spills must be documented and reported according to Section 2.3.6 of the CGP.

PERFORMANCE:

- ◆ Onsite equipment fueling BMPs are expected to protect stormwater to the extent that no fuel, oil, or solvents are allowed to pollute waters of the state or storm water conveyances.

REFERENCE:

- ◆ CGP 2.3.1

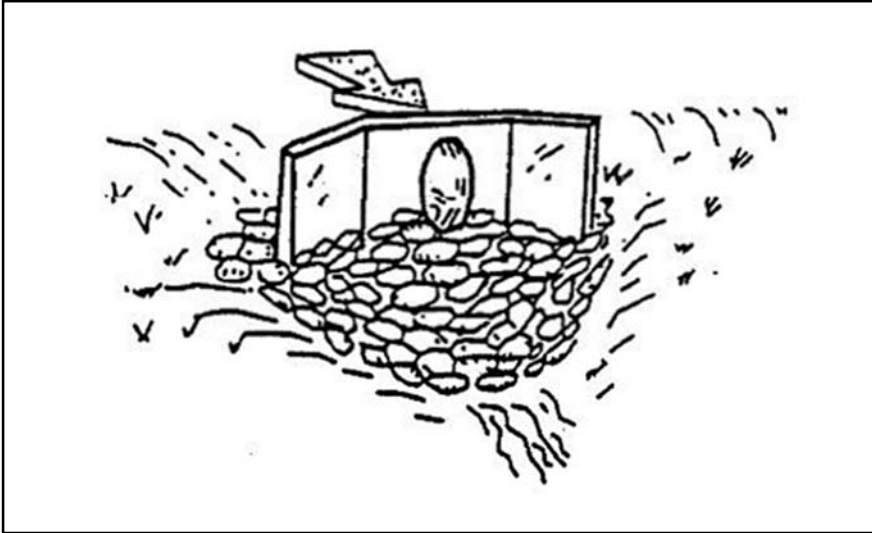
**DESCRIPTION:**

A rock outlet protection is a physical device composed of rock, grouted riprap, or concrete rubble which is placed at the outlet of a pipe to prevent scour of the soil caused by high pipe flow velocities, and to absorb flow energy to produce non-erosive velocities.

APPLICATIONS:

- ◆ Wherever discharge velocities and energies at the outlets of culverts, conduits, or channels are sufficient to erode the next downstream reach.
- ◆ Rock outlet protection is best suited for temporary use during construction because it is usually less expensive and easier to install than concrete aprons or energy dissipaters.
- ◆ A sediment trap below the pipe outlet is recommended if runoff is sediment laden.
- ◆ Permanent rock riprap protection should be designed and sized by the engineer as part of the culvert, conduit or channel design.
- ◆ Grouted riprap should be avoided in areas of freeze and thaw because the grout will break up.

INSTALLATION/APPLICATION CRITERIA:

- ◆ Rock outlet protection is effective when the rock is sized and placed properly. When this is accomplished, rock outlets do much to limit erosion at pipe outlets. Rock size should be increased for high velocity flows. Best results are obtained when sound, durable, angular rock is used.

LIMITATIONS:

- ◆ Large storms often wash away the rock outlet protection and leave the area susceptible to erosion.
- ◆ Sediment captured by the rock outlet protection may be difficult to remove without removing the rock.
- ◆ Outlet protection may negatively impact the channel habitat.

MAINTENANCE:

- ◆ Inspect after each significant rain for erosion and/or disruption of the rock, and repair immediately.
- ◆ Grouted or wire-tied rock riprap can minimize maintenance requirements.

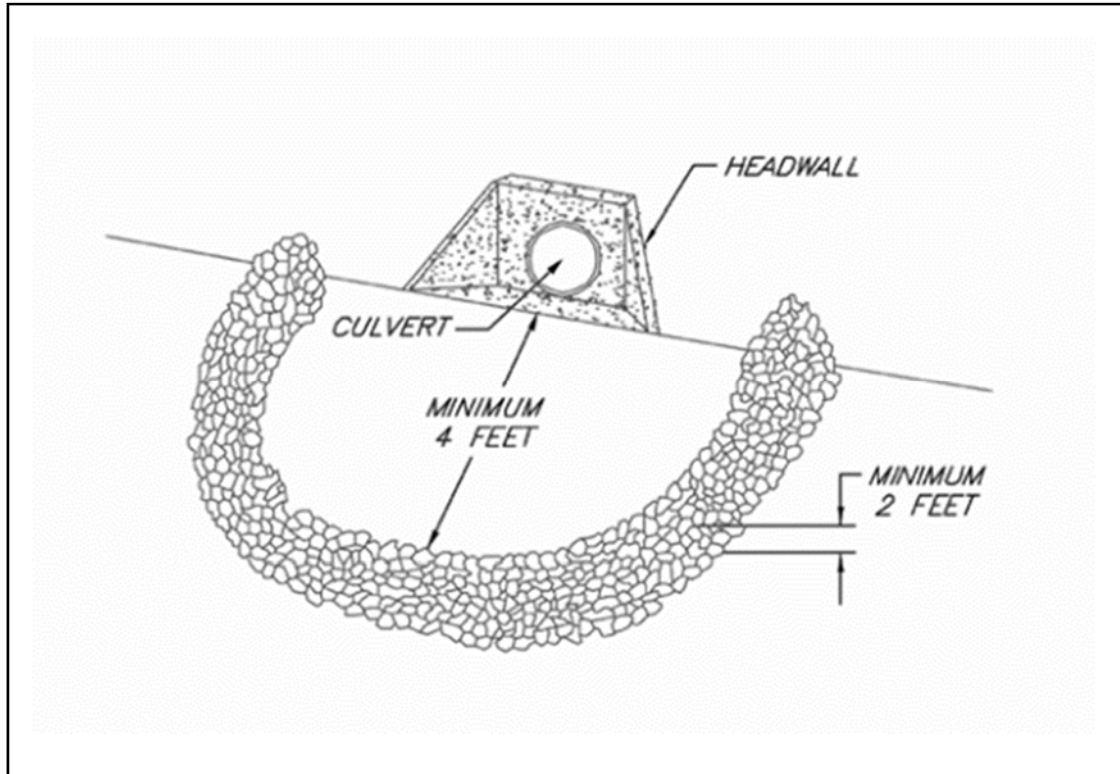

APPLICATION:

A culvert inlet sediment barrier is a temporary rock barrier at a culvert inlet. The purpose of the barrier is to reduce the amount of sediment that enters the culvert by creating a small ponding area for the sediment to settle out.

- ◆ For use on a site with open culverts within the project area that are exposed to runoff.

INSTALLATION/USE PROCEDURES:

- ◆ A geotextile should be placed between the stone barrier and the natural ground.
- ◆ Surround all sides of the culvert with Class II Channel Lining at a minimum of 4 feet from the culvert.
- ◆ The barrier must be designed to ensure that no bypasses occur up to 0.5" of rainfall
- ◆ Control the location of the sediment barrier spillway by placing an overflow notch at a selected location in the middle portion of the barrier.
 - The notch should be at least six inches lower than the rest of the barrier.
 - The down gradient portion of the overflow notch should be protected from erosion caused by potential spillover with Class II Channel Lining.
- ◆ The upstream face of the barrier should consist of smaller stone to decrease the flow rate through the stone.
- ◆ If a culvert inlet sediment barrier is intended to be used for long-term storm water management, design and installation must be approved by an accredited engineer.

OPERATOR BMP MODIFICATION OR REPLACEMENT:

- ◆ Operator is invited to propose an alternative BMP or modify this preferred BMP. The proposed BMP must match or exceed performance requirements as this preferred BMP.

Any deviations from this preferred BMP must be reviewed and accepted by the oversight authority.

- ◆ Submit BMP modifications or replacements to the oversight authority for review; including but not limited to; Proprietary system literature, modified illustrations, any operation procedures and maintenance adjustments, etc.

MAINTENANCE/MANAGEMENT:

- ◆ Inspect the condition of the sediment barrier weekly and after every rainfall event greater than one-half inch. Erosion and scouring would necessitate barrier reinforcement.
- ◆ Remove sediment and/or debris when depth reaches one-half the height of the barrier.

PERFORMANCE:

- ◆ A culvert inlet sediment barrier is expected to utilize sediment deposition to the maximum extent possible before allowing runoff to enter the culvert.
- ◆ The overflow spillway should not compromise the capacity of the berm to slow the flow of the first half inch of rain.

REFERENCE:

- ◆ CGP 2.2.11
- ◆ CPP 2.3

APPLICATION:

- ◆ Use for pavement cutting on directly connected pavements or where cutting dust can be washed to drainage systems, especially in curb and gutter applications.

INSTALLATION/USE PROCEDURES:

- ◆ Schedule cutting during dry weather periods.
- ◆ Remove cutting dust immediately following the cutting operation.
- ◆ Sweep until no more waste can be picked up with a square nose shovel.
- ◆ Dispose of cutting dust in a concrete waste container or regular waste management container.

OPERATOR BMP MODIFICATION OR REPLACEMENT:

- ◆ Operator is invited to propose an alternative BMP or modify this preferred BMP. The proposed BMP must match or exceed performance requirements as this preferred BMP. Any deviations from this preferred BMP must be reviewed and accepted by the oversight authority.
- ◆ Submit BMP modifications or replacements to the oversight authority for review; including but not limited to; Proprietary system literature, modified illustrations, any operation procedures and maintenance adjustments, etc.

MAINTENANCE/MANAGEMENT:

- ◆ BMP is installed and removed with each cutting operation, no maintenance is necessary.

PERFORMANCE:

- ◆ BMP application success would be that dust is contained to the cutting operation area and disposed per BMP.

It is considered a BMP failure when any of the following occur:

- ◆ Cutting dust enters drainage systems
- ◆ Cutting operations are not cleaned up immediately following the cutting operation
- ◆ Any waste material is not disposed per BMP or otherwise can contaminate water resources

REFERENCE:

- ◆ CGP 2.3.4
- ◆ CPP 2.9.1

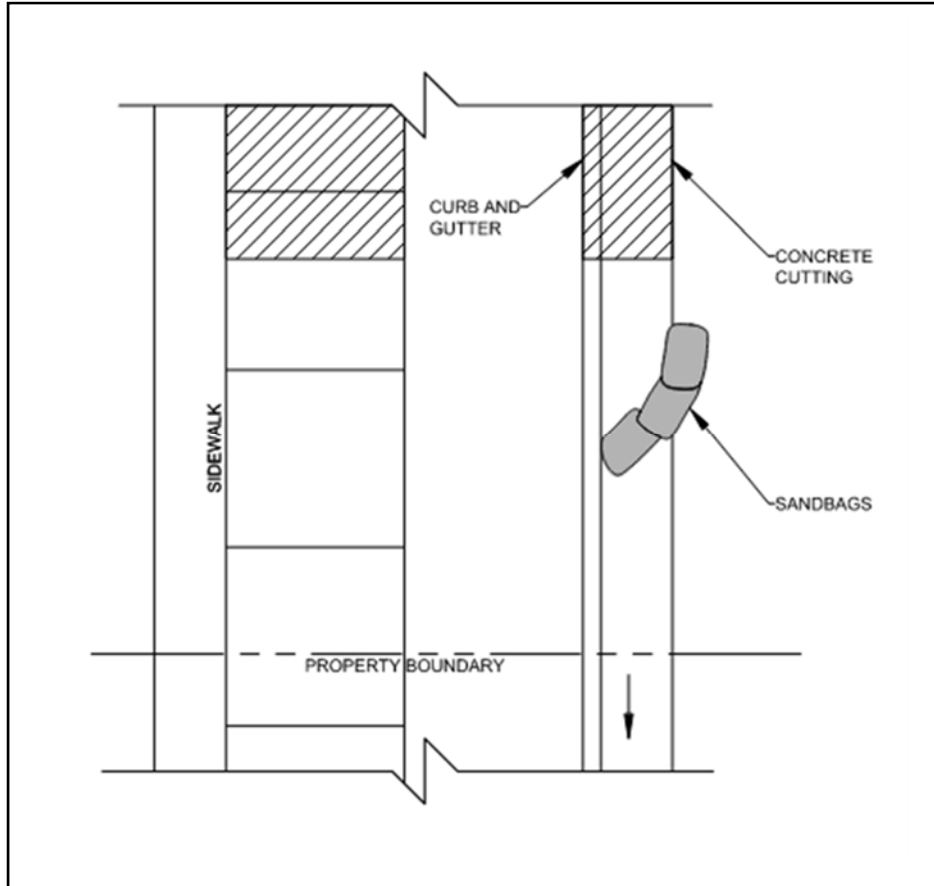

APPLICATION:

- ◆ Use Pavement Saw Cutting-Wet BMP when cutting pavement with wet saw, especially in curb and gutter applications.
- ◆ Appropriate for use when dry cutting is not allowed or dust control is desired.

INSTALLATION/USE PROCEDURES:

- ◆ Install 6” min diameter sand or gravel bags in a manner to contain slurry from moving downslope from the cutting operation. Double up bags as necessary.
- ◆ Install enough bags anticipating the volume of cut slurry.
- ◆ Schedule cutting during dry weather periods.
- ◆ Remove slurry at the end of day or prior to rain events whichever comes first. When wet conditions exist, mix slurry with dirt or other absorbing material and remove immediately.
 - Dump waste in concrete washout containment system.
 - Dry the waste in a contained area and dispose of waste in regular waste management container.
- ◆ Sweep until no more waste can be picked up with a square nose shovel.
- ◆ Do not use water to rinse slurry from the cutting operation area, dry clean-up methods only as described above.

OPERATOR BMP MODIFICATION OR REPLACEMENT:

- ◆ Operator is invited to propose an alternative BMP or modify this preferred BMP. The proposed BMP must match or exceed performance requirements as this preferred BMP. Any deviations from this preferred BMP must be reviewed and accepted by the oversight authority.
- ◆ Submit BMP modifications or replacements to the oversight authority for review; including but not limited to; Proprietary system literature, modified illustrations, any operation procedures and maintenance adjustments, etc.

MAINTENANCE/MANAGEMENT:

- ◆ BMP is installed and removed with each cutting operation, no maintenance is necessary.

PERFORMANCE:

- ◆ Utilizing water during saw cutting is a great way to capture dust from cutting operations so that dust does not travel out of the cutting operation area nor pollute the air.
- ◆ Additionally utilization of this BMP will prevent high density opacity for nearby drivers and operators.
- ◆ Performance criteria to judge application success would be that airborne dust does not occur and slurry is contained and disposed per BMP.

It is considered a BMP failure when any of the following occur:

- ◆ The dam created with sand or gravel bags overflows
- ◆ Cutting operations are not cleaned up by the end of day or prior to wet conditions.
- ◆ Any waste material is not disposed per BMP or otherwise can contaminate water resources

REFERENCE:

- ◆ CGP 2.3.4
- ◆ CPP 2.9.1



APPLICATION:

- ◆ This BMP is necessary when construction activities generate significant amounts of sediment-laden water that needs to be managed to prevent environmental contamination.
- ◆ Use this BMP when: The site requires the temporary storage and treatment of sediment-laden water due to construction activities such as excavation, dewatering, or stormwater runoff collection.

INSTALLATION/USE PROCEDURES:

- ◆ **Placement:** position the portable sediment tank (frac-tank) on a flat, stabilized surface, away from storm drains and water bodies. Identify these locations on the site plan.
- ◆ **Connection:** ensure all hoses and connections are secure and leak-free. Properly connect the inlet and outlet hoses to direct sediment-laden water into the tank.
- ◆ **Filling:** gradually fill the tank with sediment-laden water, allowing sediments to settle out. Avoid overfilling the tank.
- ◆ **Sediment removal:** periodically remove accumulated sediments from the tank according to proprietary specifications to maintain capacity and effectiveness. Follow appropriate disposal methods for the removed sediments.
- ◆ **Discharge:** discharge the treated water in compliance with local regulations, ensuring that it meets the required water quality standards.
- ◆ **Training:** ensure the workforce is informed about the correct operation and maintenance procedures for portable sediment tank (frac-tank).

OPERATOR BMP MODIFICATION OR REPLACEMENT:

- ◆ Operator is invited to propose an alternative BMP or modify this preferred BMP. The proposed BMP must match or exceed performance requirements as this preferred BMP. Any deviations from this preferred BMP must be reviewed and accepted by the oversight authority.
- ◆ Submit BMP modifications or replacements to the oversight authority for review; including but not limited to; Proprietary system literature, modified illustrations, any operation procedures and maintenance adjustments, etc.

MAINTENANCE/MANAGEMENT:

- ◆ Inspect the portable sediment tank (frac-tank) and associated equipment for leaks, damage, and proper functioning.
- ◆ Ensure that sediment levels are monitored and sediments are removed as needed to maintain tank capacity.
- ◆ Applicant is expected to modify the portable sediment tank system, location and capacity when necessary as site conditions and operations warrant.

PERFORMANCE:

- ◆ Ensure that the discharge from the frac-tank meets local, state, and federal water quality standards for sediment and turbidity. Any discharge with visible sediment or cloudiness constitutes failure and requires immediate corrective action.
- ◆ Any leak or spill around the tank area indicates BMP failure.
- ◆ Sediment within the tank must be kept below the manufacturer's recommended level.

REFERENCE:

- ◆ CGP 2.2.12, 7.3.5, A.2.4

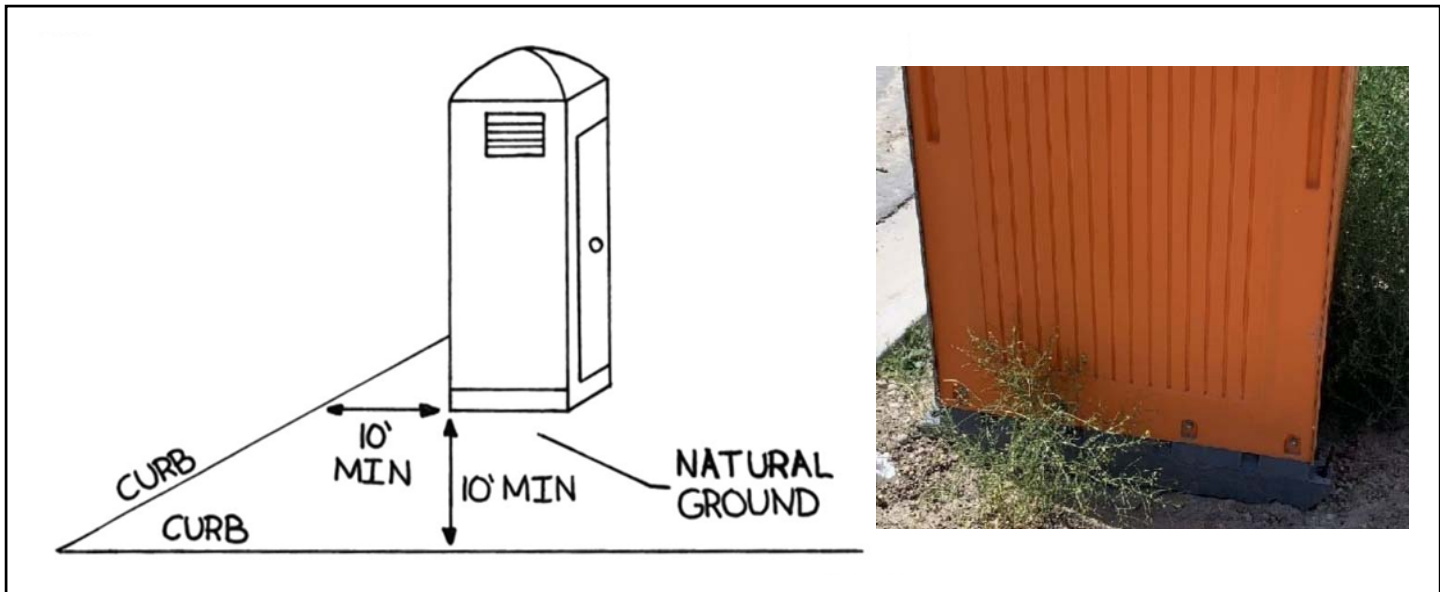

APPLICATION:

Provide temporary sanitary facilities when permanent facilities are too far from activities or are unavailable.

INSTALLATION/USE PROCEDURE:

Locate portable toilets away from waters of the state, and at least 10 feet from any storm water conveyance, inlet, curb and gutter, or conduit to a waterway.

- ◆ Wherever possible, locate portable toilet upon natural ground and not on impervious surfaces such as asphalt, concrete, or similar
- ◆ Prepare a level surface and provide clear access to the toilet(s) for servicing and for on-site personnel
- ◆ Wherever possible, locate a portable toilet next to track out pad or provide gravel access pad for maintenance pick up to reduce occurrence of mud track out by service provider.
- ◆ Secure portable toilets to prevent tipping e.g. stakes, tie downs, etc.

OPERATOR BMP MODIFICATION OR REPLACEMENT:

- ◆ Operator is invited to propose an alternative BMP or modify this preferred BMP. The proposed BMP must match or exceed performance requirements as this preferred BMP. Any deviations from this preferred BMP must be reviewed and accepted by the oversight authority.
- ◆ Submit BMP modifications or replacements to the oversight authority for review; including but not limited to; Proprietary system literature, modified illustrations, any operation procedures and maintenance adjustments, etc.

Also see Portable Toilet on Pavement

MAINTENANCE/MANAGEMENT:

Portable toilets should be maintained in good working order by licensed service

- ◆ Portable toilets should be inspected daily to detect any leaks

- ◆ Damaged toilets must be repaired/replaced immediately
- ◆ All waste must be deposited in the sanitary sewer system for treatment with appropriate agency approval
- ◆ Implement spill BMP immediately upon spill incident
- ◆ If track out from the service provider occurs, debris must be removed as soon as practicable.

PERFORMANCE:

- ◆ A portable toilet is expected to contain human waste with zero exposure to storm water.
- ◆ A successful portable toilet is clean, effective, and is processed by the appropriate licensed facility.

REFERENCE:

- ◆ CGP 2.3.3(f)
- ◆ CPP 2.4.4



APPLICATION:

- ◆ Use portable toilets on pavement only for projects without pervious staging areas. Usually projects within existing right-of-ways.
- ◆ Do not install portable toilets on pavement when private property is expected to be used. Generally, portable toilets installed on pavement are not acceptable for commercial and residential projects.

INSTALLATION/USE PROCEDURE:

- ◆ When near inlets, always locate portable toilets downstream of inlets. Identify on SWPPP BMP map.
- ◆ Place portable toilet on a surface no steeper than 2% grade.
- ◆ Attach portable toilet contractor illustrations, service and any maintenance information. For ground mount toilets provide each corner with 50# weights or as specified by the service contractor. For trailer mounted systems, provide a plan for securing the trailer as specified by the service contractor.
- ◆ Provide secondary containment. Submit for oversight authority review. A gutter dam BMP is a good choice.
- ◆ Obtain private or public right of way encroachment permit (or local equivalent) when required by the local authority.
- ◆ Attach a copy of the portable toilet manufacturer's maintenance literature.
- ◆ Ensure the spill prevention program includes containment materials and protocols for potential portable toilet spills.
- ◆ Ensure maintenance personnel and site workers involved in site operations understand BMP requirements.

OPERATOR BMP MODIFICATION OR REPLACEMENT:

- ◆ Operator is invited to propose an alternative BMP or modify this preferred BMP. The proposed BMP must match or exceed performance requirements as this preferred BMP. Any deviations from this preferred BMP must be reviewed and accepted by the oversight authority.
- ◆ Submit BMP modifications or replacements to the oversight authority for review; including but not limited to; Proprietary system literature, modified illustrations, any operation procedures and maintenance adjustments, etc.

MAINTENANCE/MANAGEMENT:

- ◆ Inspect BMP location corresponds with SWPPP BMP map. Locations are often dynamic for projects within right-of-ways.
- ◆ Inspect maintenance per manufacturer requirements
- ◆ Inspect for leaks and tank levels
- ◆ Inspect anti-tipping system

PERFORMANCE:

- ◆ A portable toilet is expected to contain human waste with zero exposure to storm water.
- ◆ A successful portable toilet is clean, effective, and is processed by the appropriate licensed facility.

REFERENCE:

- ◆ CGP 2.3.3(f), 2.4.4
- ◆ CPP 2.4.4

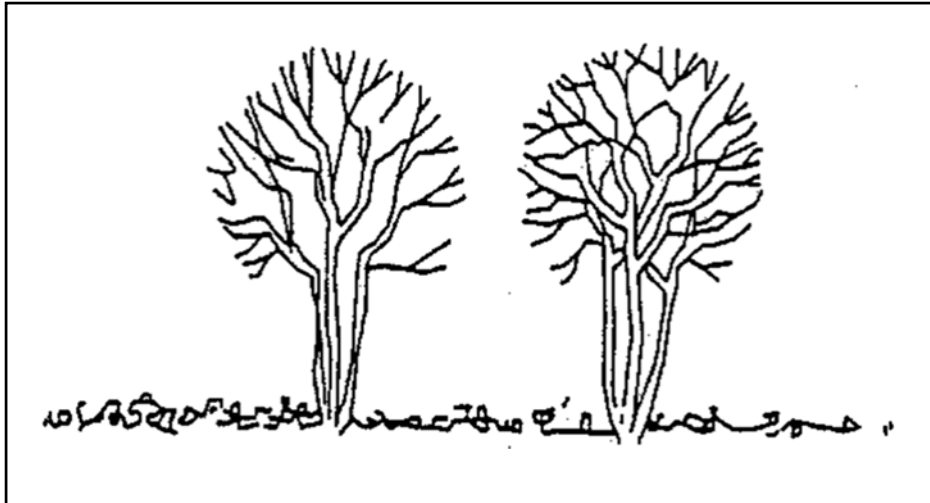
**DESCRIPTION:**

Carefully planned preservation of existing vegetation minimizes the potential of removing or injuring existing trees, vines, shrubs and/or grasses that serve as erosion controls.

APPLICATIONS:

- ◆ This technique is applicable to all types of sites. Areas where preserving vegetation can be particularly beneficial are floodplains, wetlands, stream banks, steep slopes, and other areas where erosion controls would be difficult to establish, install, or maintain.

INSTALLATION/APPLICATION CRITERIA:

- ◆ Clearly mark, flag or fence vegetation or areas where vegetation should be preserved.
- ◆ Prepare landscaping plans which include as much existing vegetation as possible and state proper care during and after construction.
- ◆ Define and protect with berms, fencing, signs, etc. a setback area from vegetation to be preserved.
- ◆ Propose landscaping plans which do not include plant species that compete with the existing vegetation.
- ◆ Do not locate construction traffic routes, spoil piles, etc. where significant adverse impact on existing vegetation may occur.

LIMITATIONS:

- ◆ Requires forward planning by the owner/developer, contractor and design staff.
- ◆ For sites with diverse topography, it is often difficult and expensive to save existing trees while grading the site satisfactorily for the planned development.
- ◆ May not be cost effective with high land costs.

MAINTENANCE:

- ◆ Inspection and maintenance requirements for protection of vegetation are low.
- ◆ Maintenance of native trees or vegetation should conform to landscape plan specifications.

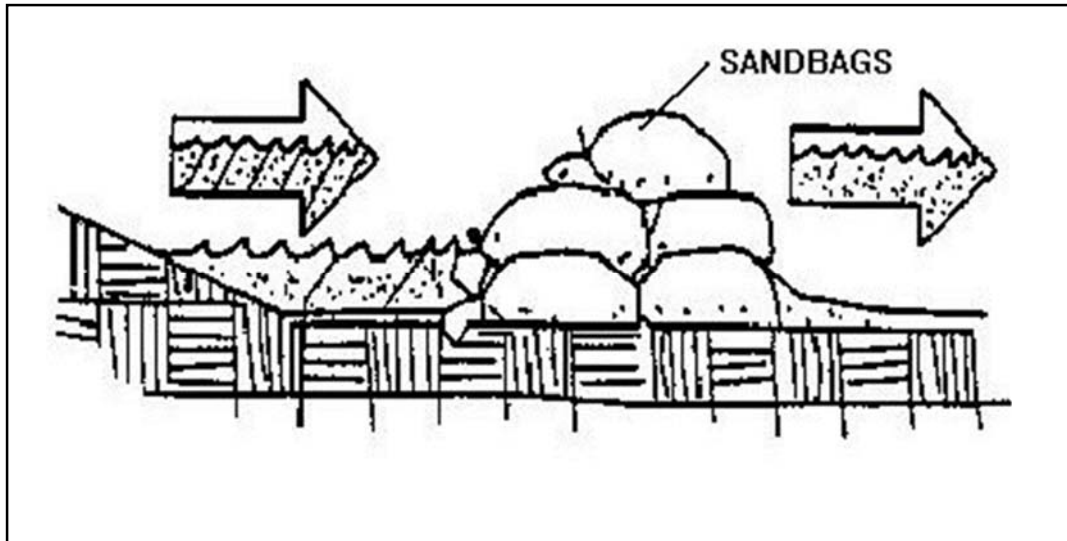
**DESCRIPTION:**

Stacking sandbags along a level contour creates a barrier which detains sediment-laden water, ponding water upstream of the barrier and promoting sedimentation.

APPLICATIONS:

- ◆ Along the perimeter of the site.
- ◆ May be used in drainage areas up to 5 acres.
- ◆ Along streams and channels
- ◆ Across swales with small catchments.
- ◆ Around temporary spoil areas.
- ◆ Below the toe of a cleared slope.

INSTALLATION/APPLICATION CRITERIA:

- ◆ Install along a level contour.
- ◆ Base of sandbag barrier should be at least 48 inches wide.
- ◆ Height of sandbag barrier should be at least 18 inches high.
- ◆ 4 inch PVC pipe may be installed between the top layer of sand bags to drain large flood flows.
- ◆ Provide area behind barrier for runoff to pond and sediment to settle.
- ◆ Place below the toe of a slope.

LIMITATIONS:

- ◆ Sandbags are more expensive than other barriers, but also more durable.
- ◆ Burlap should not be used.

MAINTENANCE:

- ◆ Inspect after each rain event.
- ◆ Reshape or replace damaged sandbags immediately.
- ◆ Replace sediment when it reaches six inches in depth.

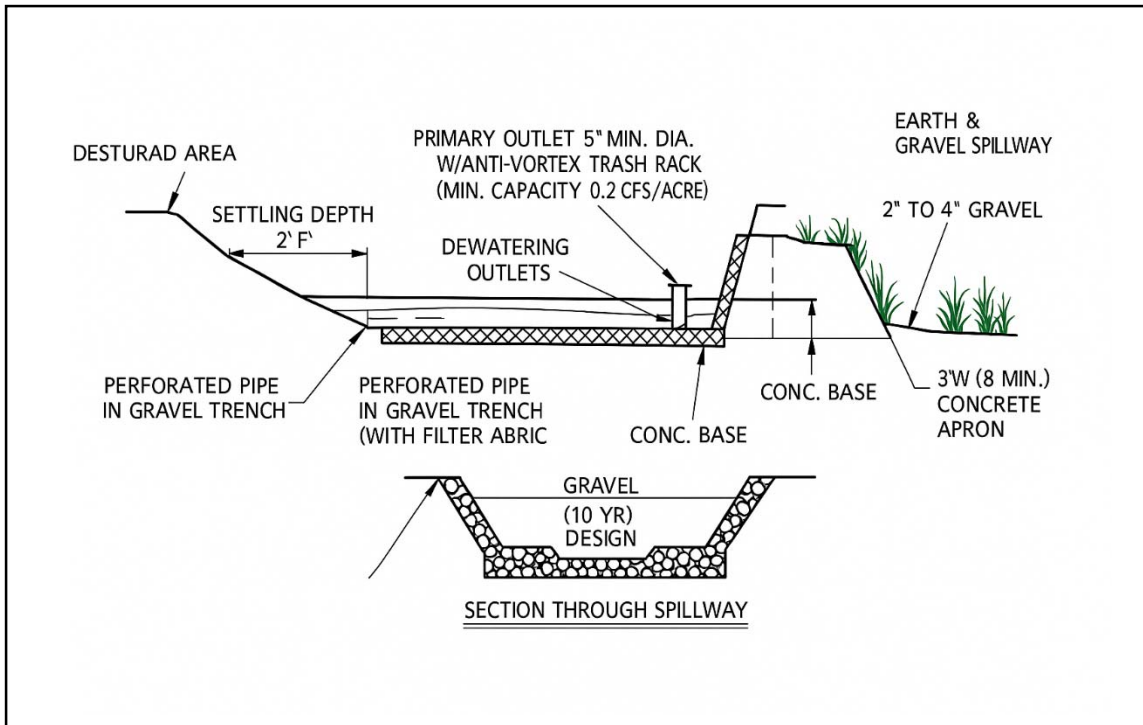

DESCRIPTION:

A pond created by excavation or construction of an embankment, and designed to retain or detain runoff sufficiently to allow excessive sediment to settle. Sediment basins serve as treatment devices which can be used on a variety of project types.

APPLICATION:

- ◆ Large areas of land drain to the basin
- ◆ At the outlet of disturbed watersheds 10 acres or larger
- ◆ At the outlet of smaller watersheds as necessary
- ◆ Where post construction basins will be located
- ◆ for disturbed upstream drainage areas of 5 acres or more

INSTALLATION/APPLICATION CRITERIA:

- ◆ Design basin for site specific location, maintain effective flow length 2 times width.
- ◆ Excavate basin or construct compacted berm containment, ensure no down gradient hazard if failure should occur. (Provide minimum of 67 cy. per acre of drainage area).
- ◆ Construct dewatering and outfall structure and emergency spillway with apron.
- ◆ Use erosion controls and velocity dissipation devices to prevent erosion at inlets and outlets.
- ◆ Sediment basins and ponds must be installed only within the property limits where failure of the structure would not result in loss of life, damage to homes or buildings, or interruption of use or service of public roads or utilities.
- ◆ Sediment basins and ponds are attractive to children and can be very dangerous. Local ordinances regarding health and safety must be adhered to. If fencing of the pond is required, the type of fence and its location should be shown on the Stormwater Pollution Prevention Plan (SWPPP).

- ◆ Because of additional detention time, sediment basins may be capable of trapping smaller sediment particles than traps. However, they are most effective when used in conjunction with other BMPs such as seeding or mulching.
- ◆ Sediment basins can be converted to permanent structures after completion of the construction project. Remove all excess sediment from the basin. The containment volume must meet the design specifications of the approved plan set. The inside of a permanent sediment basin should be stabilized to meet local and UPDES requirements.

LIMITATIONS:

- ◆ Should be sized based on anticipated runoff, sediment loading and drainage area size.
- ◆ May require silt fence at outlet for entrapment of very fine silts and clays.
- ◆ May require safety fencing to prevent public access.
- ◆ Height restrictions for embankment may be regulated.

MAINTENANCE:

- ◆ Inspect after each rainfall event and at a minimum of monthly.
- ◆ Repair any damage to berm, spillway or sidewalls and outlet structures or mechanisms.
- ◆ Remove accumulated sediment as it reaches 2/3 height of available storage.
- ◆ Check outlet for sedimentation/erosion of down gradient area and remediate as necessary, and/or install down gradient BMPs as necessary.
- ◆ Install silt fence if sedimentation apparent.

PERFORMANCE:

- ◆ Sediment basins are at best only 70-80 percent effective in trapping sediment which flows into them. Therefore, they should be used in conjunction with erosion control practices such as temporary seeding, mulching, diversion dikes, etc. to reduce the amount of sediment flowing into the basin.
- ◆ A type of outlet being used with increasing frequency is the floating skimmer. Some early tests indicate that the skimmer (which draws water only from the surface) might be more effective at retaining sediment in the basin than the standard riser and barrel configuration.

REFERENCE:

- ◆ CGP 2.2.12, 7.3.5

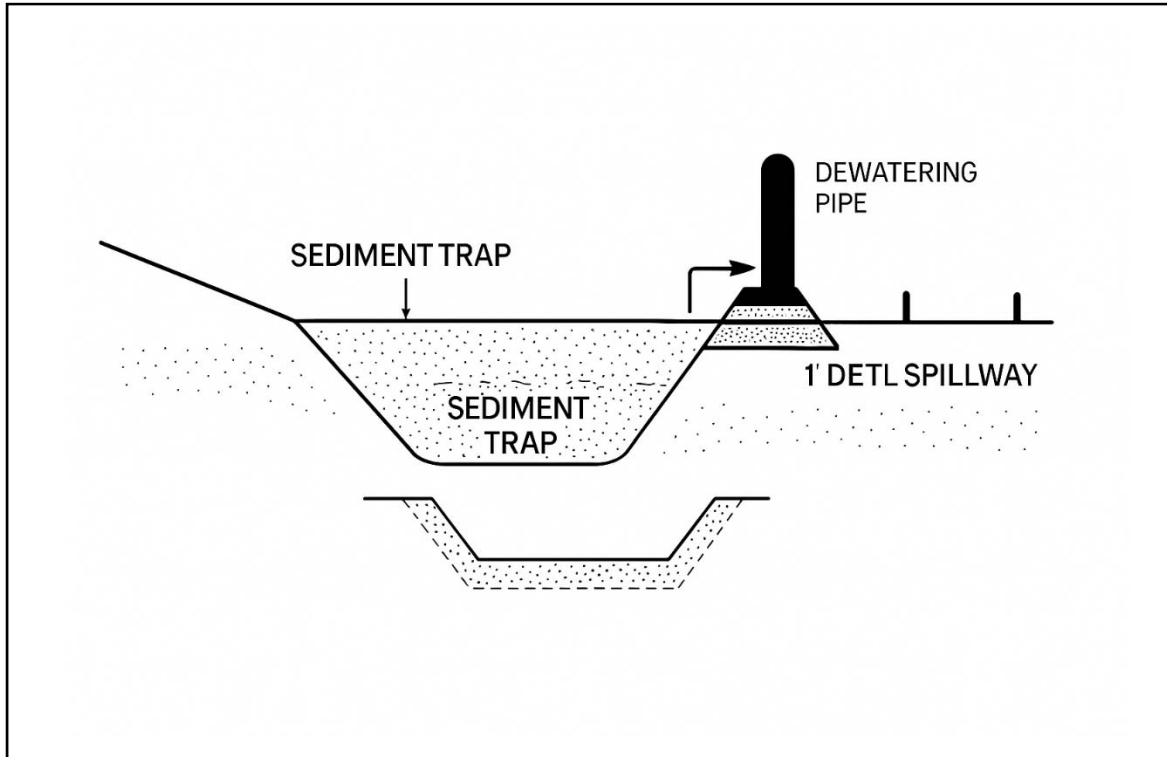

DESCRIPTION:

A sediment trap is a small excavated or bermed area where runoff from small drainage areas is detained and sediment can settle.

APPLICATION:

- ◆ Temporary control for runoff from disturbed areas of less than 3 acres.
- ◆ Temporary control for discharge from diversion dike, surface benching, or other temporary drainage measures.

INSTALLATION CRITERIA:

- ◆ Design basin for site specific location.
- ◆ Excavate basin or construct compacted berm containment.
- ◆ Construct outfall spillway with apron.
- ◆ Provide downstream silt fence if necessary.

LIMITATIONS:

- ◆ Should be sized based on anticipated runoff, sediment loading and drainage area size.
- ◆ May require silt fence at outlet for entrapment of very fine silts and clays.

MAINTENANCE:

- ◆ Inspect after each rainfall event and at a minimum of monthly.
- ◆ Repair any damage to berm, spillway or sidewalls.
- ◆ Remove accumulated sediment as it reaches 2/3 height of available storage.
- ◆ Check outlet for sedimentation/erosion of down gradient area and remediate as necessary.

Install silt fence if sedimentation apparent.

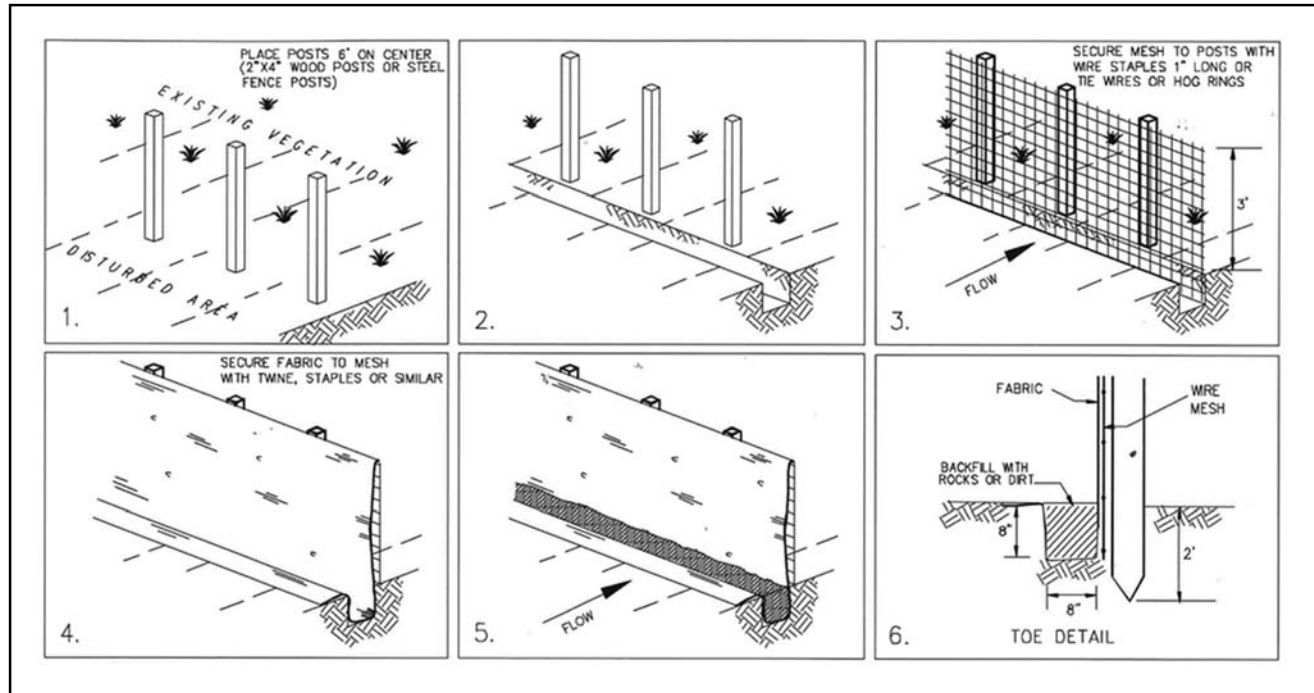

DESCRIPTION:

A temporary sediment barrier consisting of entrenched filter fabric stretched across and secured to supporting posts.

APPLICATIONS:

- ◆ Perimeter control: place barrier at down-gradient limits of disturbance
- ◆ Sediment barrier: place barrier at toe of slope or soil stockpile
- ◆ Protection of existing waterways: place barrier at top of stream bank
- ◆ Inlet protection: place fence surrounding catch basins

INSTALLATION/APPLICATION CRITERIA:

- ◆ Install silt fence per detail dimensions, description and materials or -
- ◆ For proprietary systems attach all design, performance, installation, maintenance requirements and the proprietary BMP detail documents. All requirements of this BMP remain except for any differences necessary to achieve design performance.
- ◆ Place posts 6 feet apart on center along contour (or use preassembled unit) and drive 2 feet minimum into ground. Excavate an anchor trench immediately up-gradient of posts.
- ◆ Secure wire mesh (14 gage min. with 6-inch openings) to upslope side of posts. Attach with heavy duty 1 inch long wire staples, tie wires or hog rings.
- ◆ Cut fabric to required width, unroll along length of barrier and drape over barrier. Secure fabric to mesh with twine, staples, or similar, with trailing edge extending into anchor trench.
- ◆ Backfill trench over filter fabric to anchor.

LIMITATIONS:

- ◆ Recommended maximum drainage area of 0.5 acre per 100 feet of fence
- ◆ Recommended maximum up-gradient slope length of 150 feet
- ◆ Recommended maximum uphill grade of 2:1 (50%)
- ◆ Recommended maximum flow rate of 0.5 cfs
- ◆ Ponding should not be allowed behind fence

MAINTENANCE:

- ◆ Inspect immediately after any rainfall and at least daily during prolonged rainfall.
- ◆ Look for runoff bypassing ends of barriers or undercutting barriers.
- ◆ Repair or replace damaged areas of the barrier and remove accumulated sediment.
- ◆ Reanchor fence as necessary to prevent shortcutting.
- ◆ Remove accumulated sediment when it reaches $\frac{1}{2}$ the height of the fence.

PERFORMANCE:

- ◆ A silt fence allows water to pass trapping sediment behind. Runoff going around, under or over silt fence would indicate a silt fence system failure.
- ◆ A silt fence is expected to filter sediment for storm events less than 2yr 24hr storm events. Fence failures for events less than a 2yr 24hr storm feasibly means the silt fence was either designed, installed, was unmaintained, was damaged by construction operations or the silt fence was not the best BMP for the site exposure. When the area tributary to the fence results in runoff rates greater than silt fence design capability, provide conveyance swales and retention pond BMPs or as per other CGP options.

REFERENCE:

- ◆ CGP 2.2.3, 2.2.5, 2.2.11, 2.2.12, 7.3.3

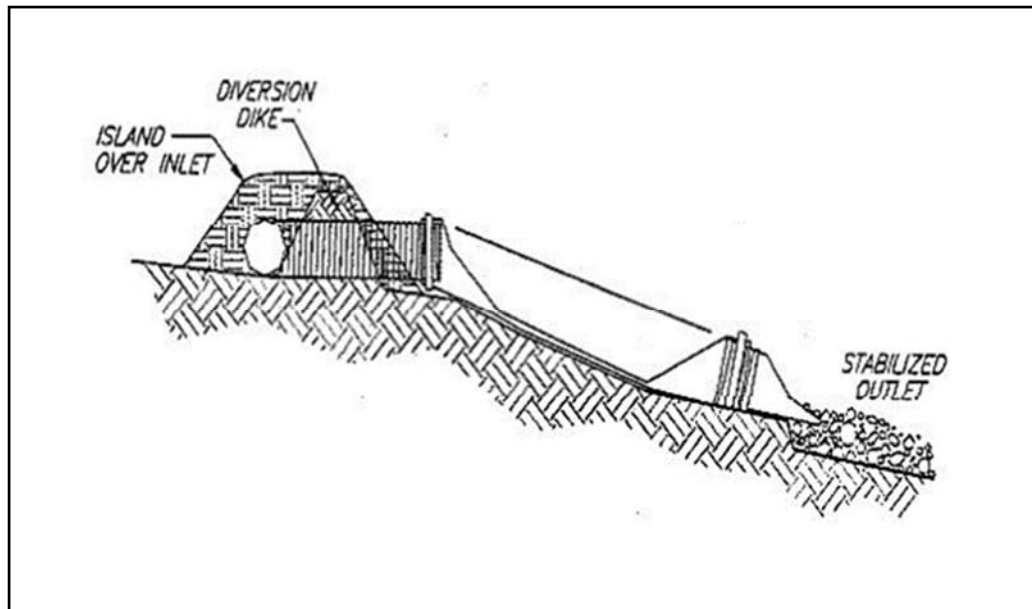
**DESCRIPTION:**

A temporary pipe or lined channel that drains the top of a slope to a stable discharge point at the bottom of a slope without causing erosion.

APPLICATIONS:

- ◆ Where concentrated flow of surface runoff must be conveyed down a slope in order to prevent erosion.
- ◆ Drainage for top slope diversion dikes or swales.
- ◆ Emergency spillway for a sediment basin.
- ◆ Drainage for top of cut/fill slopes where water can accumulate.

INSTALLATION/APPLICATION CRITERIA:

- ◆ Secure inlet and surround with dikes to prevent gully erosion, and anchor pipe to slope.
- ◆ Size to convey at least the peak of a 10-year, storm event.
- ◆ Stabilize outlet. (See Outlet Protection BMP).

LIMITATIONS:

- ◆ Maximum drainage area per slope drain is 5 acres.
- ◆ Clogged slope drains will force water around the pipe and cause slope erosion.
- ◆ Dissipation of high flow velocities at the pipe outlet is required to avoid downstream erosion.
- ◆ Failure can result in flooding and severe erosion.

MAINTENANCE:

- ◆ Structure must be inspected weekly and after storms.
- ◆ Inlet must be free of undercutting and no water should circumvent the entry.
- ◆ Outlet should not produce erosion; velocity dissipators must be maintained.
- ◆ Pipe anchors must be checked to ensure that the pipe remains anchored to the slope.

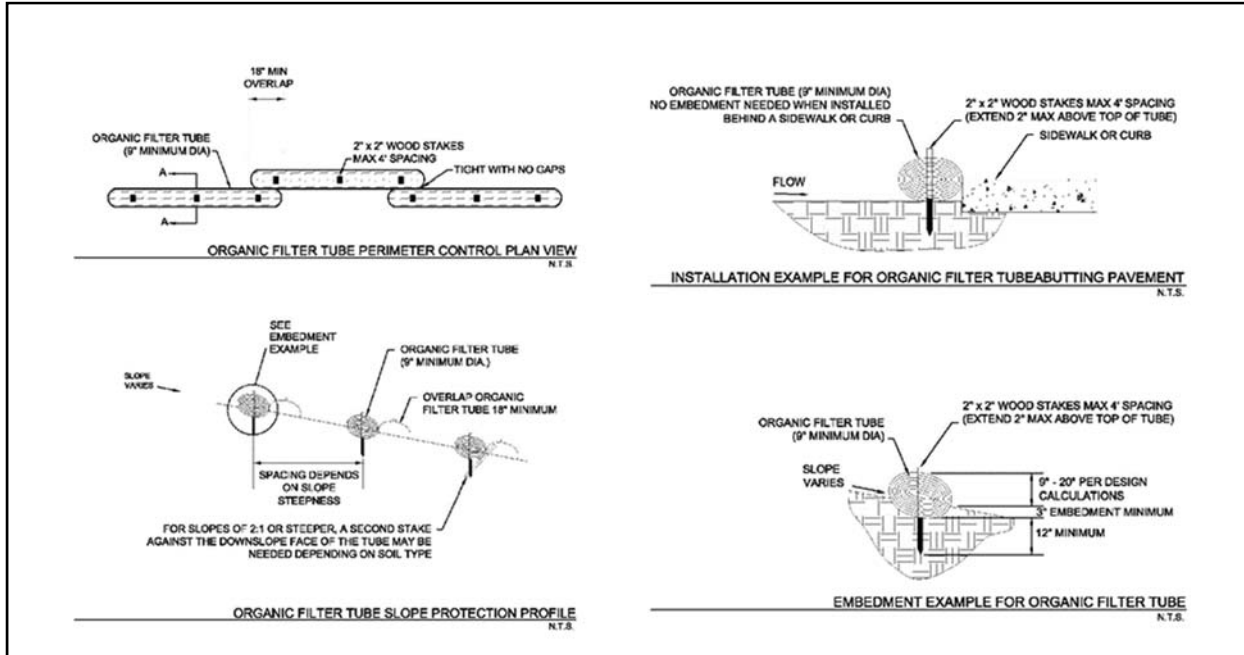

APPLICATIONS:

Filter tubes are also called fiber rolls, fiber logs, wattles, mulch socks, and/or coir rolls. The tubes can be filled with organic material (compost, wood chips, straw, coir, aspen fiber, or a mixture of materials) or geosynthetic material. Though filter tubes have many uses, this BMP focuses on slope management.

- ◆ If the tubes will be left onsite as part of the final stabilization plan (such as in Arid and Semi-Arid areas with exceptions to final stabilization timeline requirements) they must be constructed of 100 percent biodegradable jute, coir, sisal or similar natural fiber or 100 percent UV photodegradable plastic, polyester or geosynthetic material.
- ◆ Filter tubes can be used to treat sheet flow over a short distance and can be used on steep slopes as both sediment and erosion control.
- ◆ Filter tubes work by detaining flow and capturing sediment as a linear control along the contours of a slope, or as a perimeter control down-slope of a disturbed area (when appropriately sized).
- ◆ Filter tubes are most effective with coarse to silty soil types; additional controls may be needed to remove fine silts and clays suspended in stormwater.

INSTALLATION/USE PROCEDURES:

- ◆ Filter tubes should be installed along the contour.
- ◆ Tubes shall be staked with 2 inch by 2 inch wooden stakes at a maximum spacing of 4 feet. Rebar or similar metal stakes may be used instead of wooden stakes.
- ◆ When placed on pavement, sand or rock bags shall be placed abutting the down-slope side of the tubes to prevent runoff from dislodging the tubes. At a minimum, bags shall be placed one foot from each end of the tube and at the middle of the tube.
- ◆ Filter tubes shall be embedded a minimum of three inches when placed on soil. Placement on rock shall be designed as placement on pavement.
- ◆ The end of tubes shall overlap a minimum of 18 inches when multiple tubes are connected to form a linear control along a contour or a perimeter.

- ◆ Loose mulch material shall be placed against the log on the upstream side to facilitate contact with the ground.
- ◆ The last 10 feet (or more) at the ends of a line of tubes shall be turned upslope to prevent bypass by stormwater. Additional turned-upslope lengths of tubes may be needed every 200 to 400 linear feet, depending on the traverse slope along the line of tubes.
- ◆ The most common sizes of tubes are 6 to 24 inches in diameter; however, tubes are available in sizes as small as 4 inches and up to 36 inches in diameter. The designer shall specify a diameter based on the site application. Tubes less than 8 inches in diameter when filled will require more frequent maintenance if used.
- ◆ When using manufactured tubes, the manufacturer's recommendations for diameter and spacing based on slope, flow velocities, and other site conditions shall be followed and documented in a site's SWPPP.

MAINTENANCE:

- ◆ Organic filter tubes should be inspected regularly each inspection period.
- ◆ The filter tube should be checked to ensure that it is in continuous contact with the soil at the bottom of the embedment trench. Closely check for rill erosion that may develop under the filter tubes. Eroded spots must be repaired and monitored to prevent reoccurrence. If erosion under the tube continues, additional controls are needed.
- ◆ Staking shall be checked to ensure that the filter tubes are not moving due to stormwater runoff. Repair and re-stake slumping filter tubes. Tubes that are split, torn or unraveling shall be repaired or replaced.
- ◆ Check the filter tube material to make sure that it has not become clogged with sediment or debris. Clogged filter tubes usually lead to standing water behind the filter tube after the rain event. Sediment shall be removed from behind the filter tube before it reaches half the height of the exposed portion of the tube.

PERFORMANCE:

- ◆ Organic filter tubes are performing as intended if sheet flow of runoff is passing over or through the barrier and not simply around it, bypassing the control.
- ◆ Additionally, performance is achieved if the filter tube barrier is effectively minimizing the off-site discharge of sediment from the drainage area it is controlling and does not develop erosive rills/gullies between filter tubes and the tubes are not being undercut by erosion or eroded to either side of the barrier.
- ◆ Due to the relatively smaller sediment capture capability of these filter tubes, as compared to taller barriers, good performance will include accumulations of sediment on the upstream side of filter tubes until maintenance occurs, which will likely require more frequent maintenance.

REFERENCE:

- ◆ CGP 2.2.3, 2.2.5, 2.2.11
- ◆ CCP 2.3, 2.3.5.a

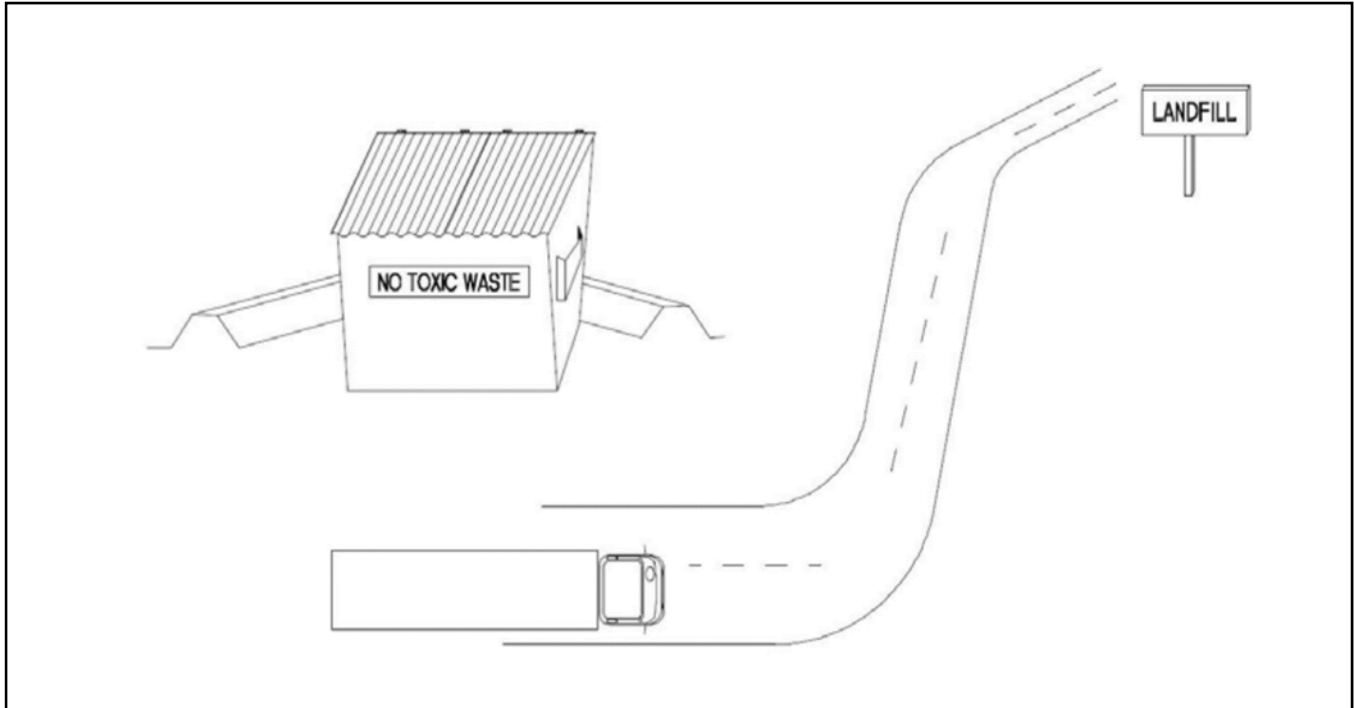

DESCRIPTION:

Controlled storage and disposal of solid waste generated by construction activities.

APPLICATIONS:

- ◆ This BMP is necessary when construction activities generate solid waste that needs to be collected and disposed of properly to prevent environmental contamination.
- ◆ Use this BMP when: The site generates solid waste, including packaging materials, scrap construction materials, masonry products, timber, pipe and electrical cuttings, plastics, styrofoam, concrete, demolition debris; and other trash or building materials that could potentially contaminate stormwater if not managed correctly.

INSTALLATION/USE PROCEDURES:

- ◆ **Selection Criteria:** Use durable, watertight containers (e.g., dumpster, trash receptacle) that are appropriately sized for the volume of waste generated on-site.
- ◆ **Placement:** position dumpsters on a flat, stabilized surface, away from storm drains and water bodies. Identify these locations on the site plan.
- ◆ **Usage:** ensure all construction waste is placed inside the dumpster. Do not overfill; waste should not extend beyond the sides or top of the dumpster. Do not dispose of liquids in this BMP. Most dumpsters and garbage trucks are not water tight.
- ◆ **Containment:** Provide containment or cover for waste that is blowable or that can leach nutrients, metals, pesticides, herbicides, oil, grease, bacteria, or other pollutants.
- ◆ **Segregation:** separate hazardous waste from non-hazardous waste and use appropriately labeled and secured containers for hazardous materials.
- ◆ Locate on parking pad or next to track-pad to prevent track-out when servicing. Show location on site BMP map.
- ◆ Do not install in roadways without approval of local municipality. This usually means obtaining a local right-of-way encroachment permit or equal to stage dumpsters in right-of-ways.

- ◆ Train workforce.

OPERATOR BMP MODIFICATION OR REPLACEMENT

- ◆ Operator is invited to propose an alternative BMP or modify this preferred BMP. The proposed BMP must match or exceed performance requirements as this preferred BMP. Any deviations from this preferred BMP must be reviewed and accepted by the oversight authority.
- ◆ Submit BMP modifications or replacements to the oversight authority for review; including but not limited to; Proprietary system literature, modified illustrations, any operation procedures and maintenance adjustments, etc.

MAINTENANCE/MANAGEMENT:

- ◆ Ensure the workforce is informed about proper waste disposal procedures and the importance of maintaining the integrity of waste management BMPs.
- ◆ Operator is expected to modify the solid waste management system, location and capacity when necessary as site conditions and operations warrant.
- ◆ Inspect dumpsters for leaks, damage, and proper cover.
- ◆ Collect any trash around the construction site daily and deposit it in the waste container at designated collection areas.
- ◆ Arrange for regular waste removal to a licensed facility often enough to prevent overfilling.
- ◆ Contain and clean up spilled waste or overflow immediately.

PERFORMANCE:

A solid waste management BMP is considered effective if:

- ◆ All construction and domestic waste generated is contained
- ◆ No incidents of dumpster overflow or leaks
- ◆ No visible waste or debris around the construction site or dumpster area

REFERENCE:

- ◆ CGP 2.2.3(e)

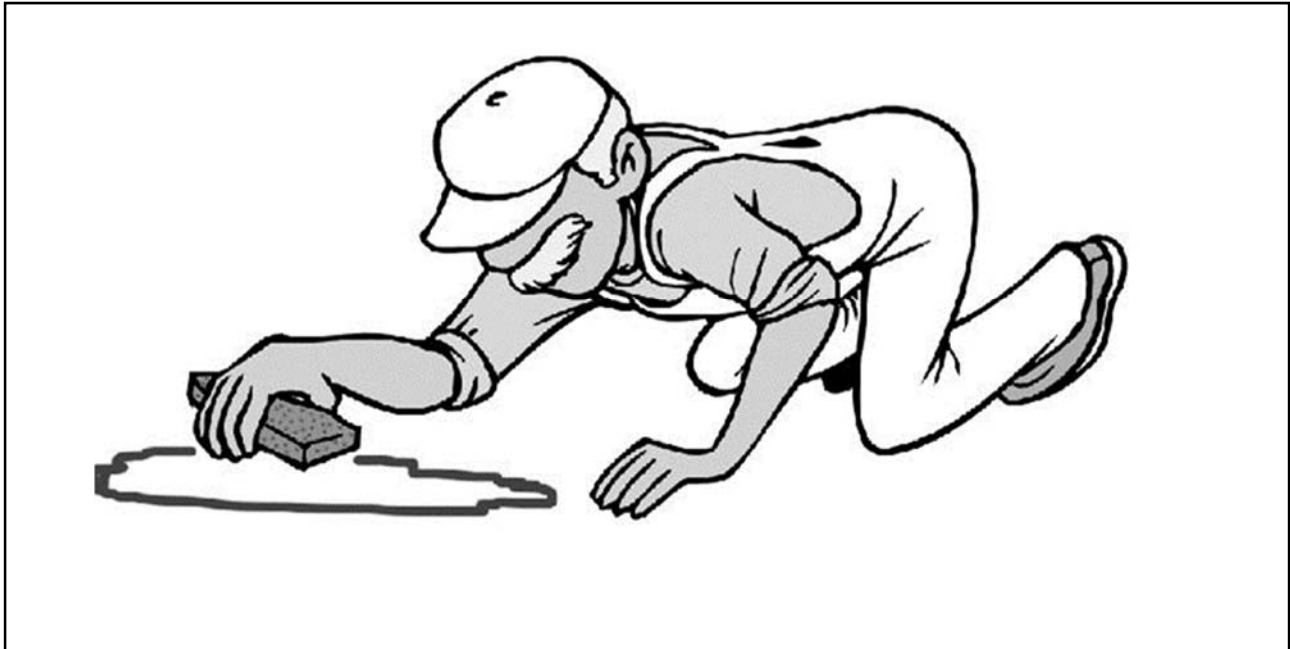

DESCRIPTION:

Practices to clean-up leakage/spillage of on-site materials that may be harmful to receiving waters.

APPLICATIONS:

All Sites

GENERAL:

- ◆ Store controlled materials within a storage area.
- ◆ Educate personnel on prevention and clean-up techniques.
- ◆ Designate an Emergency Coordinator responsible for employing preventative practices and for providing spill response.
- ◆ Maintain a supply of clean-up equipment on-site and post a list of local response agencies with phone numbers.

METHODS:

- ◆ Clean-up spills/leaks immediately and remediate cause.
- ◆ Use as little water as possible. **NEVER HOSE DOWN OR BURY SPILL CONTAMINATED MATERIAL.**
- ◆ Use rags or absorbent material for clean-up. Excavate contaminated soils. Dispose of clean-up material and soil as hazardous waste.
- ◆ Document all spills with date, location, substance, volume, actions taken and other pertinent data.
- ◆ Contact the Salt Lake County Health Department (313-6700) for any spill of reportable quantity.

APPLICATIONS:

- ◆ Projects where topsoil is stripped and will be reused at a later phase
- ◆ Projects where any natural materials must be stored on site for use throughout the project
- ◆ Projects which have an offsite stockpile area

INSTALLATION/USE PROCEDURES:

- ◆ Provide staging/storage area location(s) on the BMP map.
- ◆ For offsite storage yard or stockpiles that are used in conjunction with the project, include appropriate storm water pollution prevention controls and BMPs in the SWPPP and show the location on the site map
- ◆ Provide stockpile toe BMP when sediment is not adequately contained by other boundary BMPs. Reference other boundary BMPs managing the stockpile exposure risk.
- ◆ Ensure the workforce is informed of stockpile management requirements.

OPERATOR BMP MODIFICATION OR REPLACEMENT:

- ◆ Operator is invited to propose an alternative BMP or modify this preferred BMP. The proposed BMP must match or exceed performance requirements as this preferred BMP. Any deviations from this preferred BMP must be reviewed and accepted by the oversight authority.
- ◆ Submit BMP modifications or replacements to the oversight authority for review; including but not limited to; Proprietary system literature, modified illustrations, any operation procedures and maintenance adjustments, etc.

MAINTENANCE/MANAGEMENT:

- ◆ Employ sweeping operations at the end of the workday and as necessary.
- ◆ Train workforce when BMP improper use is recognized.

PERFORMANCE:

- ◆ Ensure all other sediment control BMPs are installed, maintained and inspected throughout storage, staging, and topsoil redistribution operations.
- ◆ Train workforce when non-containment is recognized.
- ◆ If stockpile is not being actively used, cover it and/or provide containment so that runoff cannot enter sensitive areas, waters of the state, or storm water conveyances.

REFERENCE:

- ◆ CGP 2.2.8, 7.3.3
- ◆ CPP 2.2.5, 2.2.14

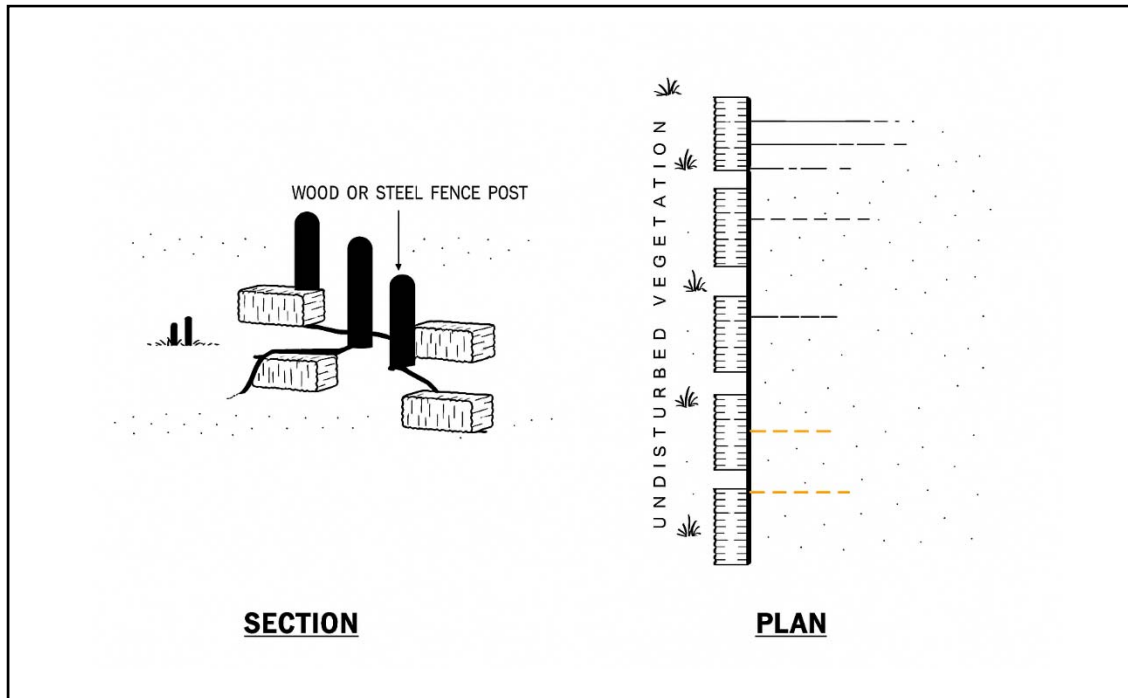

DESCRIPTION:

Temporary sediment barrier consisting of a row of entrenched and anchored straw bales.

APPLICATIONS:

- ◆ Perimeter control: place barrier at down-gradient limits of disturbance.
- ◆ Sediment barrier: place barrier at toe of slope or soil stockpile.
- ◆ Protection of existing waterways: place barrier at top of stream bank.
- ◆ Inlet protection.

INSTALLATION/APPLICATION CRITERIA:

- ◆ Excavate a 4-inch minimum deep trench along contour line, i.e. parallel to slope, removing all grass and other material that may allow underflow.
- ◆ Place bales in trench with ends tightly abutting, fill any gaps by wedging loose straw into openings.
- ◆ Anchor each bale with 2 stakes driven flush with the top of the bale.
- ◆ Backfill around bale and compact to prevent piping, backfill on uphill side to be built up 4- inches above ground at the barrier.

LIMITATIONS:

- ◆ Recommended maximum area of 0.5 acre per 100 feet of barrier
- ◆ Recommended maximum up-gradient slope length of 150 feet
- ◆ Recommended maximum uphill grade of 2:1 (50%)

MAINTENANCE:

- ◆ Inspect immediately after any rainfall and at least daily during prolonged rainfall.
- ◆ Look for runoff bypassing ends of barriers or undercutting barriers.
- ◆ Repair or replace damaged areas of the barrier and remove accumulated sediment.
- ◆ Realign bales as necessary to provide continuous barrier and fill gaps.
- ◆ Recompress soil around barrier as necessary to prevent piping.
- ◆ Grouted or wire-tied rock riprap can minimize maintenance requirements.

**DESCRIPTION:**

Reduce the discharges of pollutants to stormwater from street surfaces by conducting street cleaning on a regular basis.

APPLICATIONS:

- ◆ Prioritize cleaning to use the most sophisticated sweepers, at the highest frequency, and in areas with the highest pollutant loading.
- ◆ Restrict street parking prior to and during sweeping.
- ◆ Increase sweeping frequency just before the rainy season.
- ◆ Proper maintenance and operation of sweepers greatly increase their efficiency.
- ◆ Keep accurate operation logs to track programs.
- ◆ Sweepers effective at removing smaller particles (less than 10 microns) may generate dust that would lead to concerns over worker and public safety.
- ◆ Equipment selection can be key for this particular BMP. There are two types used, the mechanical broom sweepers (more effective at picking up large debris and cleaning wet streets), and the vacuum sweepers (more effective at removing fine particles and associated heavy metals). Many communities find it useful to have a compliment of both types in their fleet.
- ◆ A Sweeping BMP is necessary to address the immediate safety, water quality and complaint issues that exist resulting from vehicle track out.
- ◆ Sweeping BMPs do not eliminate the requirement for egress track out BMPs, but are necessary to compensate for the practical limitations of most egress track out BMPs.

INSTALLATION/USE PROCEDURES:

- ◆ Use vacuum type sweeping machinery.
- ◆ Anticipate end of day sweeping or multiple times a day as needed. The better the egress track out BMP the less sweeping operations are necessary.
- ◆ A Square nose shovel and broom are also always a good roadway sediment and debris removal option.

- ◆ Identify the sweeper hopper licensed dump location. Attach dump location information to this BMP.
- ◆ Replace worn parts as necessary.
- ◆ Install main and gutter brooms of the appropriate weight.
- ◆ Ensure the workforce is trained regarding track-out BMP requirements.

LIMITATIONS:

- ◆ Conventional sweepers are not able to remove oil and grease.
- ◆ Mechanical sweepers are not effective at removing finer sediments.
- ◆ Effectiveness may also be limited by street conditions, traffic congestion, and presence of construction projects, climatic conditions and condition of curbs.

MAINTENANC/MANAGEMENT:

- ◆ Employ sweeping operations at the end of the workday and as necessary.
- ◆ Train workforce when BMP improper use is recognized.

PERFORMANCE:

- ◆ Slick conditions, slurry, mud chunks, rocks, gravel, water quality risk and driver hazards constitute BMP failure and require immediate sufficient action.
- ◆ Light tracking is expected and requires regular maintenance but not usually immediate action. Light tracking is defined as minor residual dirt that can't be picked up by a square nose shovel.
 - Remove/sweep prior to unsafe and wet conditions or end of workday, whichever is first.

REFERENCE:

- ◆ CGP 2.2.4, 5.1, 5.2.1
- ◆ CPP 2.4.1

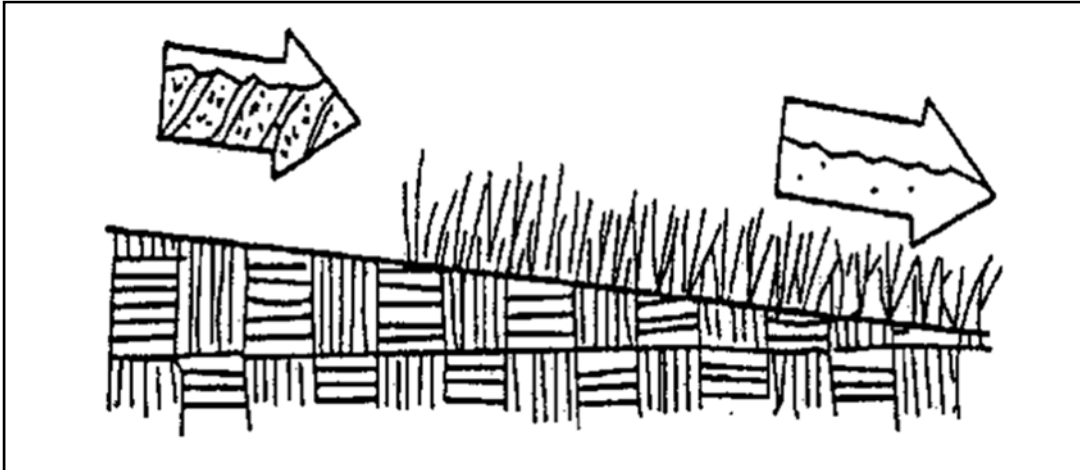
**DESCRIPTION:**

Seeding of grass and plantings of trees, shrubs, vines and ground covers provide long-term stabilization of soil. In some areas, with suitable climates, grasses can be planted for stabilization.

Temporary seeding - establishment of short term cover by application of rapidly germinating seed mix (alternatively hydro-seeding may be utilized).

Permanent seeding - establishment of final term cover by application of perennial seed mix (alternatively sod may be utilized).

APPLICATIONS:

- ◆ Appropriate for site stabilization both during construction and post-construction.
- ◆ Any graded/cleared areas where construction activities have ceased.
- ◆ Open space cut and fill areas.
- ◆ Steep slopes, spoil piles, vegetated swales, landscape corridors, stream banks.

INSTALLATION/APPLICATION CRITERIA:

- ◆ Type of vegetation, site and seedbed preparation, planting time, fertilization and water requirements should be considered for each application. The recommended seed mix will be dependent on site specific information such as elevation, exposure, soils, water availability and topography.
- ◆ Appropriate ground preparation and fertilizer must be considered.

LIMITATIONS:

- ◆ Permanent and temporary vegetation may not be appropriate in dry periods without irrigation.
- ◆ Fertilizer requirements may have potential to create stormwater pollution.

MAINTENANCE:

- ◆ Shrubs and trees must be adequately watered and fertilized and if needed pruned.
- ◆ Grasses may need to be watered and mowed.
- ◆ Provide irrigation as required to establish growth and to maintain plant cover through duration of project.
- ◆ Reseed as necessary to provide 75% coverage
- ◆ Remediate any areas damaged by erosion or traffic.
- ◆ When 75% coverage is achieved inspect monthly for damage and remediate as necessary.

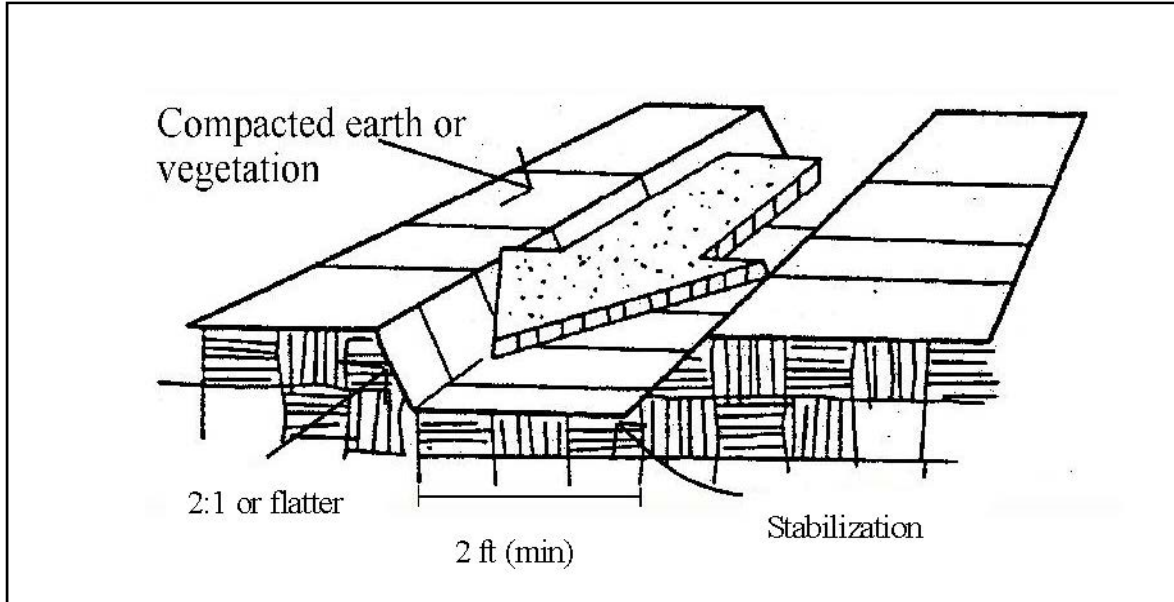
**DESCRIPTION:**

Temporary drains and swales are used to divert off-site runoff around the construction site, divert runoff from stabilized areas around disturbed areas, and direct runoff into sediment.

APPLICATIONS:

- ◆ Temporary drains and swales are appropriate for diverting any upslope runoff around unstabilized or disturbed areas of the construction site.
- ◆ Prevent slope failures. Prevent damage to adjacent property. Prevents erosion and transport of sediments into water ways. Increases the potential for infiltration. Diverts sediment-laden runoff into sediment basins or traps.

INSTALLATION/APPLICATION CRITERIA:

- ◆ Temporary drainage swales will effectively convey runoff and avoid erosion if built properly:
- ◆ Size temporary drainage swales using local drainage design criteria. A permanent drainage channel must be designed by a professional engineer (see the local drainage design criteria for proper design).
- ◆ At a minimum, the drain/swale should conform to predevelopment drainage patterns and capacities.
- ◆ Construct the drain/swale with an uninterrupted, positive grade to a stabilized outlet. Provide erosion protection or energy dissipation measures if the flow out of the drain or swale can reach an erosive velocity.

LIMITATIONS:

- ◆ Temporary drains and swales or any other diversion of runoff should not adversely impact upstream or downstream properties.
- ◆ Temporary drains and swales must conform to local floodplain management requirements.

MAINTENANCE:

- ◆ Inspect weekly and after each significant rainfall, including assessment of foundations.
- ◆ Vegetation may need to be mowed down and cleaned up for proper drainage if left unmaintained.

**DESCRIPTION:**

Vegetated buffers are areas of natural or established vegetation maintained to protect the water quality of neighboring areas. Buffer zones slow stormwater runoff, provide an area where runoff can permeate the soil, contribute to ground water recharge, and filter sediment. Slowing runoff also helps to prevent soil erosion and streambank collapse.

APPLICATIONS:

- ◆ Vegetated buffers can be used in any area able to support vegetation. They are most effective and beneficial on floodplains, near wetlands, along streambanks, and on unstable slopes.

INSTALLATION/APPLICATION CRITERIA:

To establish an effective vegetative buffer, follow these guidelines:

- ◆ Make sure soils are not compacted.
Make sure slopes are less than 5 percent unless temporary erosion control mats are also used.
- ◆ Determine buffer widths after carefully considering slope, vegetation, soils, depth to impermeable layers, runoff sediment characteristics, type and amount of pollutants, and annual rainfall.
- ◆ Make sure buffer widths increase as slope increases.
- ◆ Intermix zones of vegetation (native vegetation in particular), including grasses, deciduous and evergreen shrubs, and understory and overstory trees.
- ◆ In areas where flows are concentrated and fast, combine buffer zones with other practices such as level spreaders, infiltration areas, or diversions to prevent erosion and rilling

LIMITATIONS:

- ◆ Adequate land must be available for a vegetated buffer. If land cost is high, buffer zones might not be cost-effective. In addition, adequate vegetative cover must be maintained in the buffer to keep it effective.
- ◆ Vegetated buffers work well with sheet flows, but they are not appropriate for mitigating concentrated stormwater flows.

MAINTENANCE:

- ◆ Keeping vegetation healthy in vegetated buffers requires routine maintenance. Depending on species, soil types, and climatic conditions, maintenance can include weed and pest control, mowing, fertilizing, liming, irrigating, and pruning.

APPLICATIONS:

- ◆ Erosion and dust suppression is necessary for all areas where vegetation is removed.
- ◆ Apply vegetation removal management to minimize dust and erosion risk. Many large projects can benefit from this BMP.

INSTALLATION/USE PROCEDURES:

- ◆ Provide Stockpiling area location(s) on the BMP map.
- ◆ Attach a copy of phasing maps showing no disturbance areas for each phase. A vegetated buffer can also be utilized to provide erosion control along the outskirts of the project area.
- ◆ Ensure the workforce are informed regarding no disturbance areas.

MAINTENANC/MANAGEMENT:

- ◆ Train workforce when encroachment into no disturbance areas are found. Update no disturbance maps and SWPPP document as relevant.
- ◆ Address encroachment exposures and add or amend BMPs to compensate for the exposure as necessary.

PERFORMANCE:

- ◆ Encroachment of no disturbance phasing plan areas constitutes BMP non-compliance.

REFERENCE:

- ◆ UAC section R307-309-5
- ◆ CGP 2.2.2, 2.2.9, 2.2.6, 7.3.2.(f)
- ◆ CPP 2.2.14

EQUIPMENT CLEANING

**DESCRIPTION:**

Prevent or reduce the discharge of pollutants to storm water from vehicle and equipment cleaning by washing in designated, contained areas only, eliminating discharges to the storm drain by infiltrating or recycling the wash water, and/or training employees and subcontractors.

INSTALLATION/APPLICATION:

- ◆ Use designated, bermed wash areas to prevent wash water contact with storm water, creeks, rivers, and other water bodies. The wash area can be sloped for wash water collection and subsequent infiltration into the ground.
- ◆ Use as little water as possible to avoid having to install erosion and sediment controls for the wash area. Use phosphate-free biodegradable soaps. Educate employees and subcontractors on pollution prevention measures. Do not permit steam cleaning on-site. Steam cleaning can generate significant pollutant concentrations.

LIMITATIONS:

- ◆ Even phosphate-free, biodegradable soaps have been shown to be toxic to fish before the soap degrades.
- ◆ Sending vehicles/equipment off-site should be done in conjunction with Stabilized Construction Entrance.

MAINTENANCE:

- ◆ Minimal, some berm repair may be necessary.

BMP – Title Name

BMP CODE

CONSTRUCTION